

4

3

2

1

## OPEN CONFIGURATION

## CLOSE CONFIGURATION

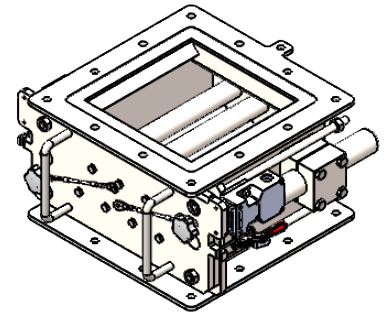
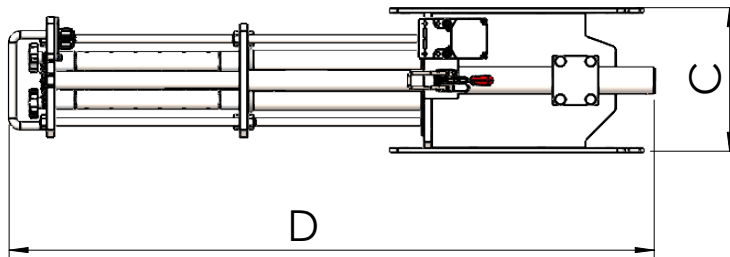
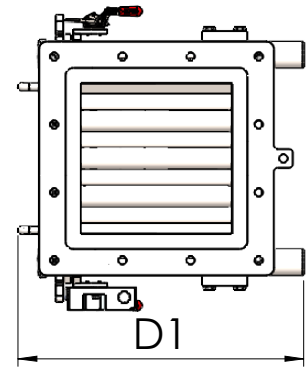
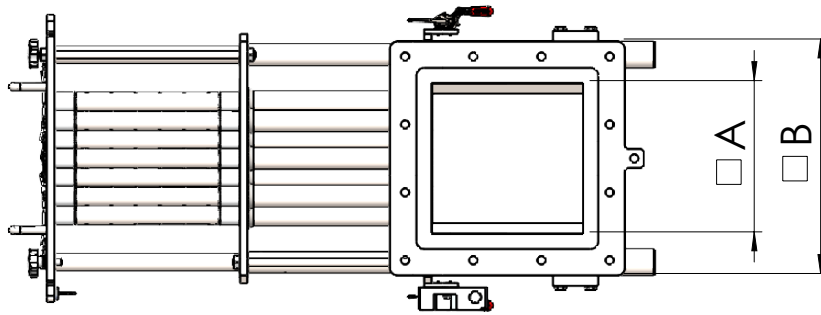

ARTICLE NO	□A	□B	C	D	D1	Q	APPROX. WEIGHT(KG)
MB_SA_F150	150	258	190	703	328	5	27
MB_SA_F200	200	310	190	853	378	7	34
MB_SA_F250	250	358	190	1003	428	9	41
MB_SA_F300	300	408	190	1153	478	11	54

## Magnet Specification

<b>Magnet Grade</b>	N48H
<b>Filter bar</b>	Ø25
<b>Quantity</b>	Q (refer Table 1)
<b>Flux Density</b>	>12000Gs

## Structure Details

<b>Material</b>	SS316L	<b>Surface Treatment</b>	Sublimation
<b>Seal Material</b>	Silicon	<b>Finishing</b>	Ra 32-4 µ in
<b>Welding</b>	Continuous with P240 radial polish		

## Recommended Parts

DM20240XXXX	Collector Plate
DM20240XXXX	Conical Adaptor
DM20240XXXX	Gasket for Rectangular Flanges

Title: Magbox Semi-Automatic EHEDG Master Drawing Article No.:

Deburr and break sharp edges  ISO 2768m-k Material:Branchweg 3, 5705 DR Helmond, The Netherlands  
+31627746820 www.dutchmagnetics.com

Scale 1:5

Units: [mm]

Treatment:

Drwn By: SJ

Date: 03-05-2024

Finish:

Appr By:

Date:

Weight: kg

Drawing No.: MB\_SA\_FXXX

A4

© Dutch Magnetics. All rights reserved. Reproduction in whole or parts is prohibited without the prior written permission of Dutch Magnetics.

State: Under Editing

Rev: 0

4

3

2

1

4

3

2

1

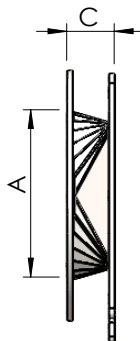
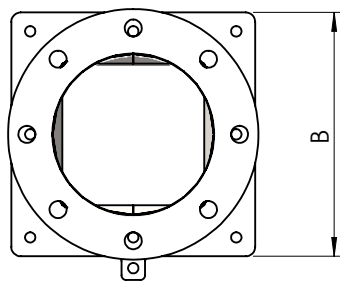

### FLANGE ADAPTOR

PART NUMBER	EXECUTION	A	B	C
DM202402394	SQ.150 TO NW80	150	258	100
DM202402399	SQ.150 TO NW100	150	258	85
DM202402388	SQ.150 TO NW125	150	258	65
DM202402389	SQ.150 TO NW150	150	258	50
DM202402404	SQ.200 TO NW200	200	310	65
DM202402408	SQ.250 TO NW250	250	358	75
DM202402414	SQ.300 TO NW300	300	408	85
DM202402413	SQ.400 TO NW350	400	510	160
DM202402418	SQ.400 TO NW400	400	510	135

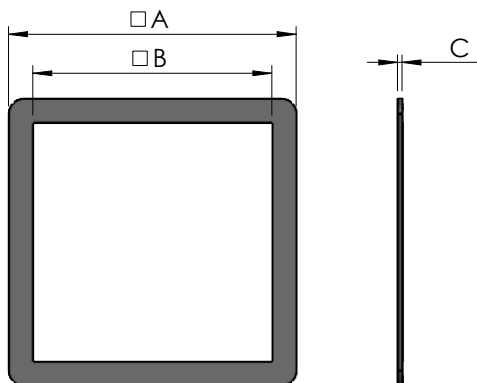

### FLANGE GASKET

PART NUMBER	SIZE	□A	□B	C
DM202402441	150	190	158	3
DM202402442	200	240	208	3
DM202402443	250	290	258	3
DM202402444	300	340	308	3
DM202402445	400	440	408	3

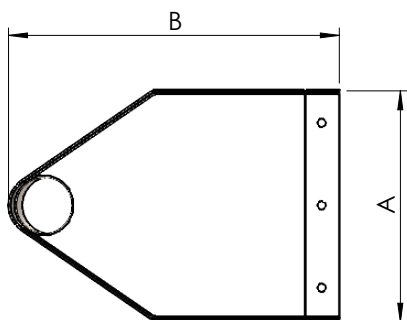

### COLLECTOR PLATE

PART NUMBER	SIZE	□A	□B
DM202401649	150	306	436.7
DM202402442	200	356	486
DM202402443	250	406	584.4
DM202402444	300	466	584.4

Title: Magbox Semi-Automatic EHEDG Master Drawing Article No.:

Deburr and break sharp edges

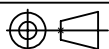

ISO 2768m-k

Material:



Branchweg 3, 5705 DR Helmond, The Netherlands  
+31627746820 www.dutchmagnetics.com

Scale 1:10

Units: [mm]

Treatment:

Drwn By: SJ

Date: 30-01-2024

Finish:

Appr By:

Date:

Weight: kg

Drawing No.: MB\_SA\_FXXX

A4

© Dutch Magnetics. All rights reserved. Reproduction in whole or parts is prohibited without the prior written permission of Dutch Magnetics.

State: Under Editing

Rev: 0

4

3

2

1

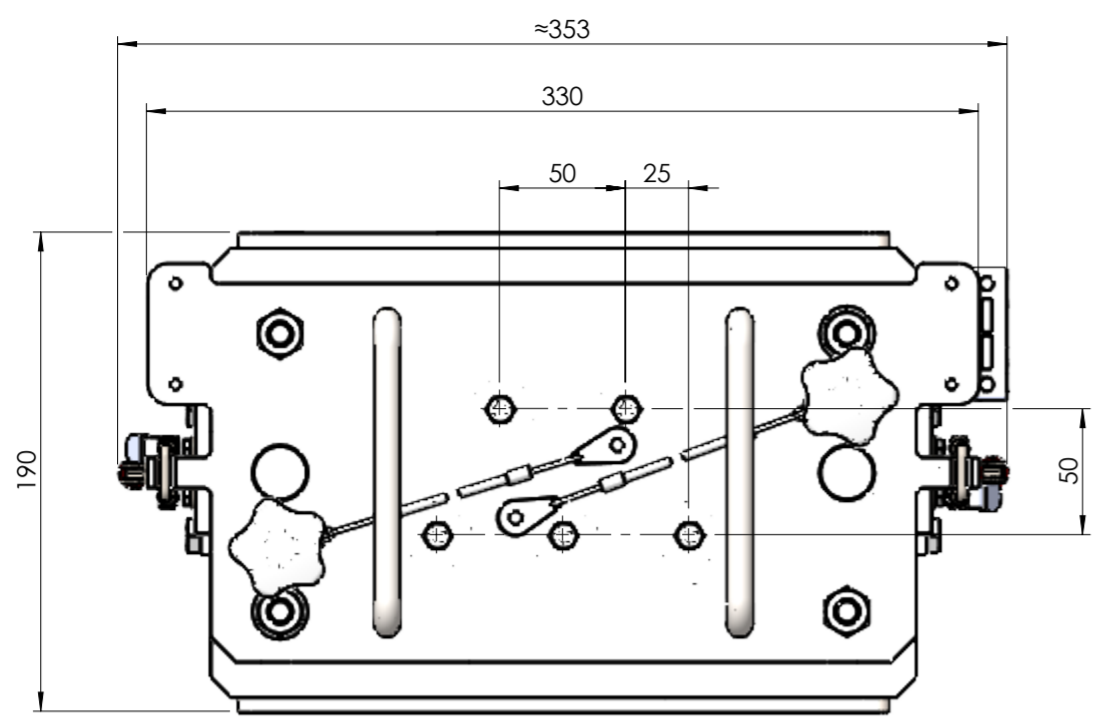

MAT. FLOW

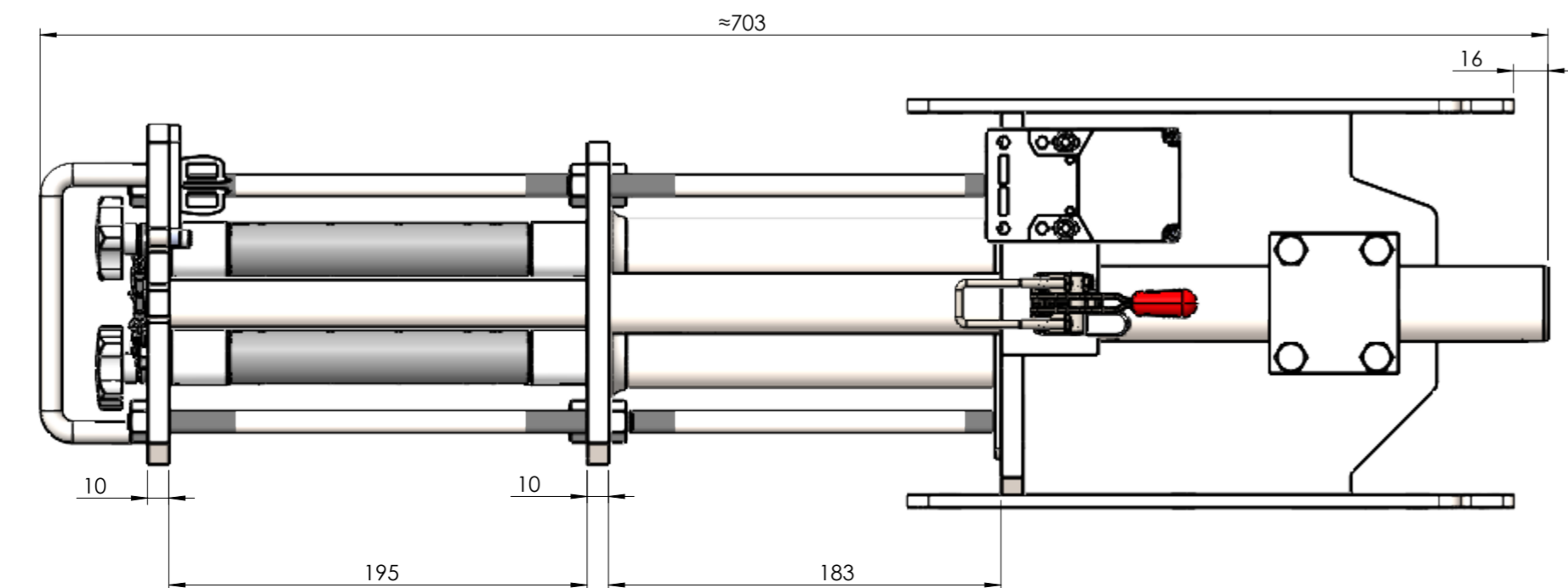
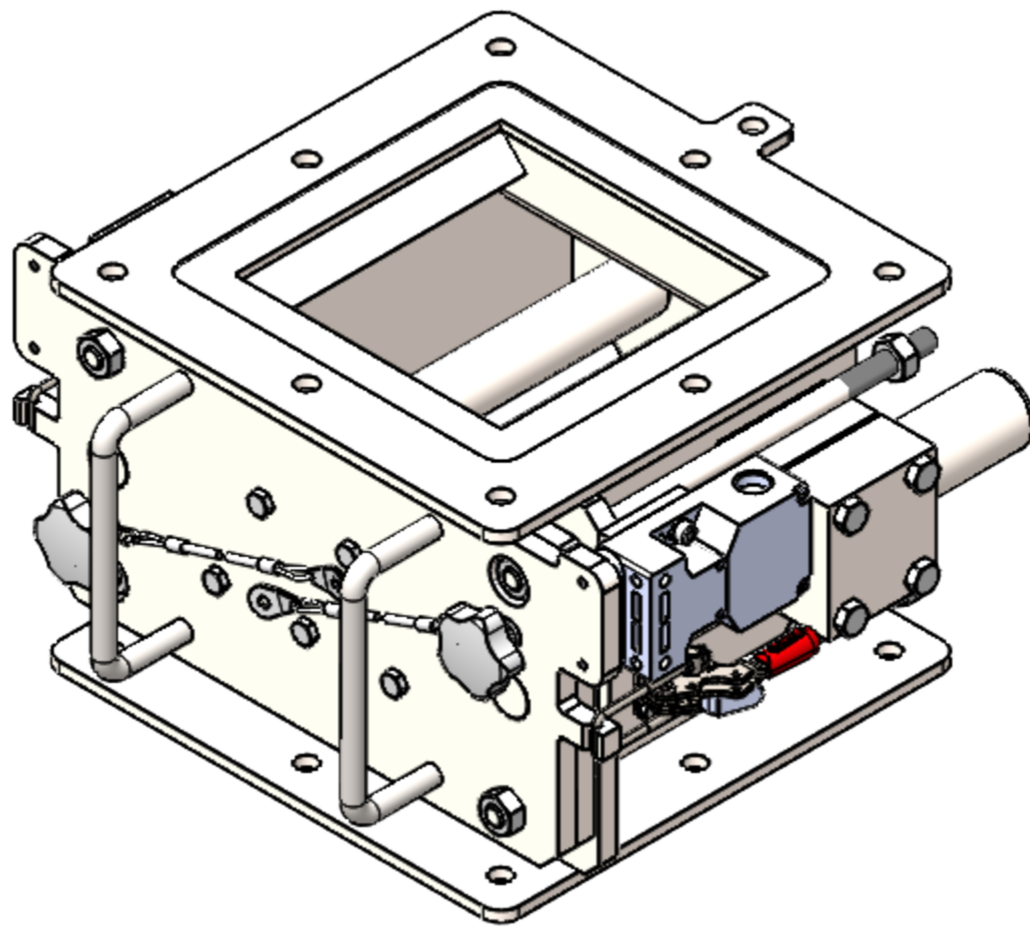
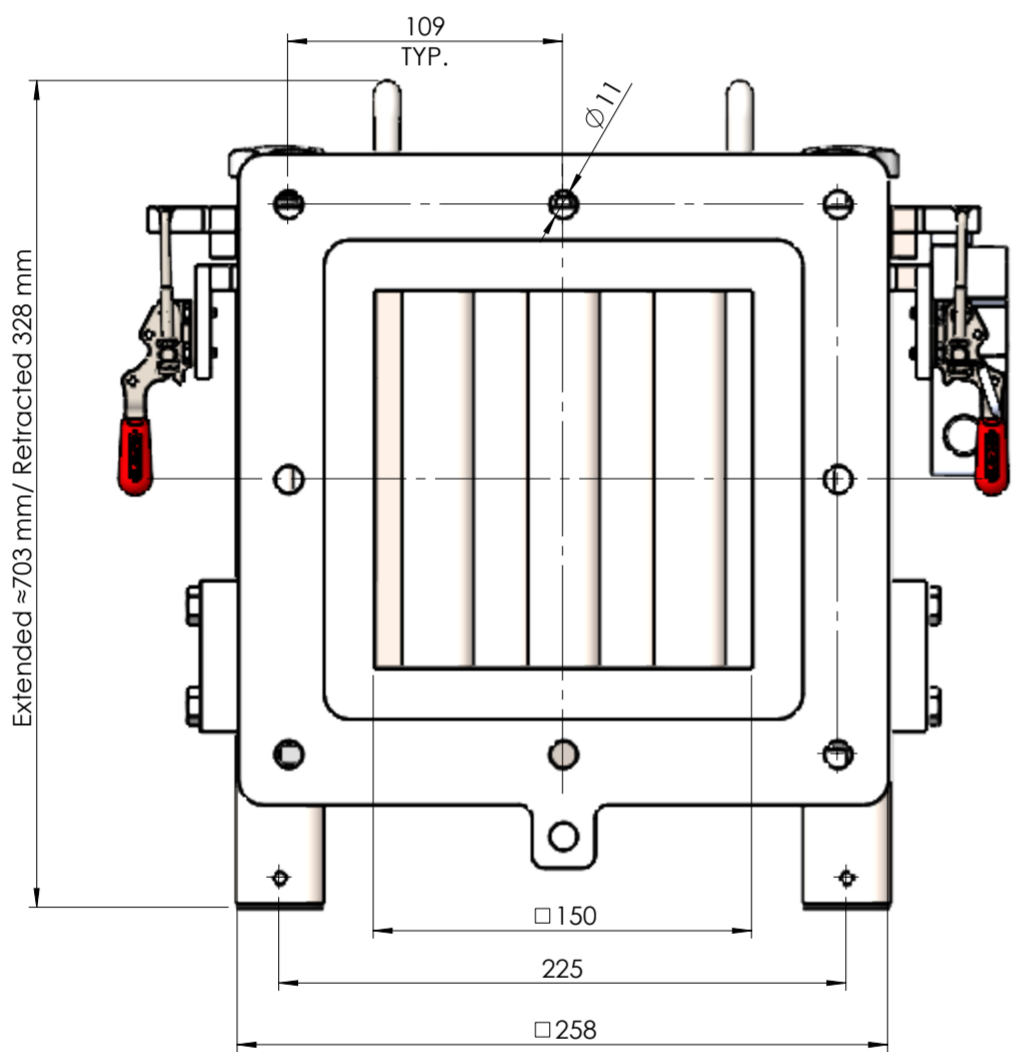
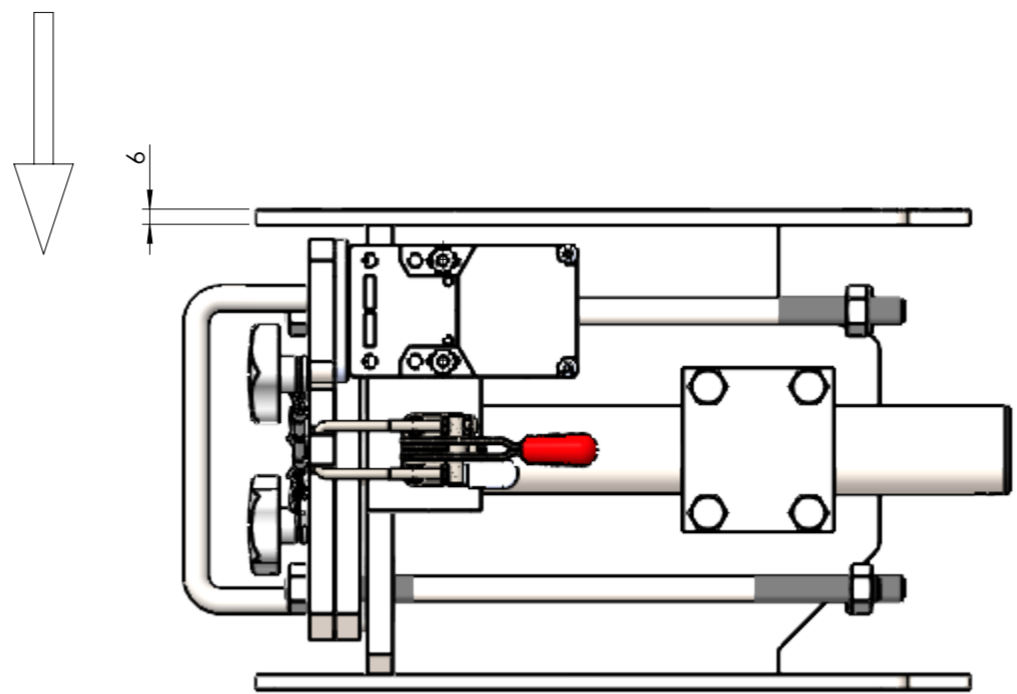

REV.	DESCRIPTION	DATE	REV. BY
0			

Magnet Specification	
Magnet Grade	48 H
Filter bar	Ø25
Quantity	5
Flux Density	>12000Gs
Structure Details	
Material	SS316L
Surface Treatment	Sublimation
Seal Material	Silicon
Finishing	Ra 32-4 µ in
Welding	Continuous with P240 radial polish
Recommended Parts	
DM202401649	Collector Plate
DM202402394	Conical Adaptor (SQ.150 TO NW80)
DM202402399	Conical Adaptor (SQ.150 TO NW100)
DM202402388	Conical Adaptor (SQ.150 TO NW125)
DM202402389	Conical Adaptor (SQ.150 TO NW150)
DM202402441	Gasket for Rectangular Flanges

Notes:  
 Safety Position Switch : Schmersal Schakelaars EEX AZ16-12 ZVRK  
 Voltage : 230 VAC / 24 VDC (2x NC / 1x NO)

Title: Magbox Semi_Automatic FOOD GRADE 150		Article No.:	
Deburr and break sharp edges		ISO 2768m-k	Material:
 Branchweg 3, 5705 DR Helmond, The Netherlands +31627746820 www.dutchmagnetics.com	Scale 1:3	Units: [mm]	Treatment:
	Drwn By: SJ	Date: 03-05-2024	Finish:
Appr By:	Date:	Weight: 27.35 kg	A2
Drawing No.: MB_SA_F_150_Master Drawing			
State: Under Editing			Rev: 0



REV.	DESCRIPTION	DATE	REV. BY
0			

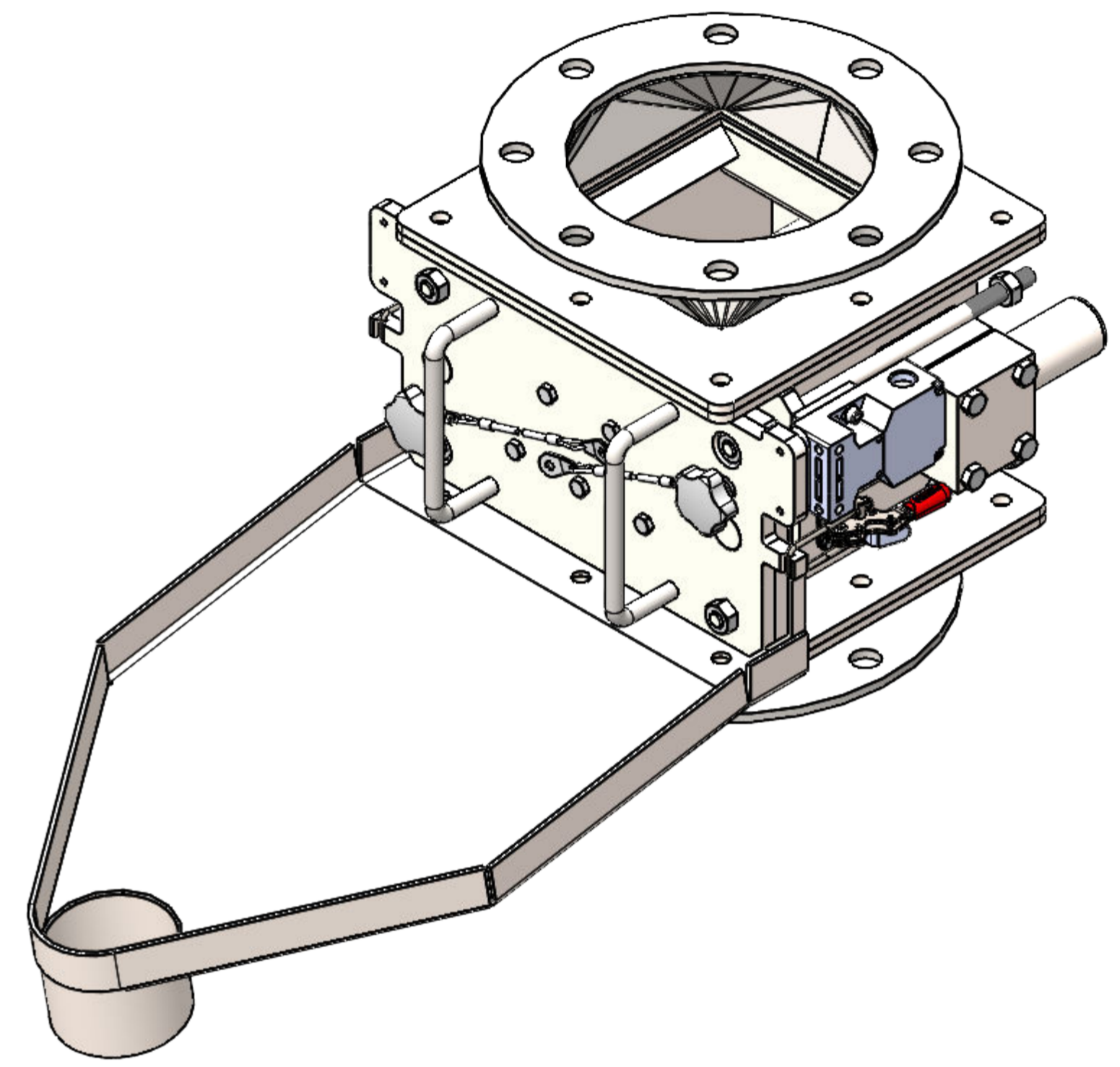
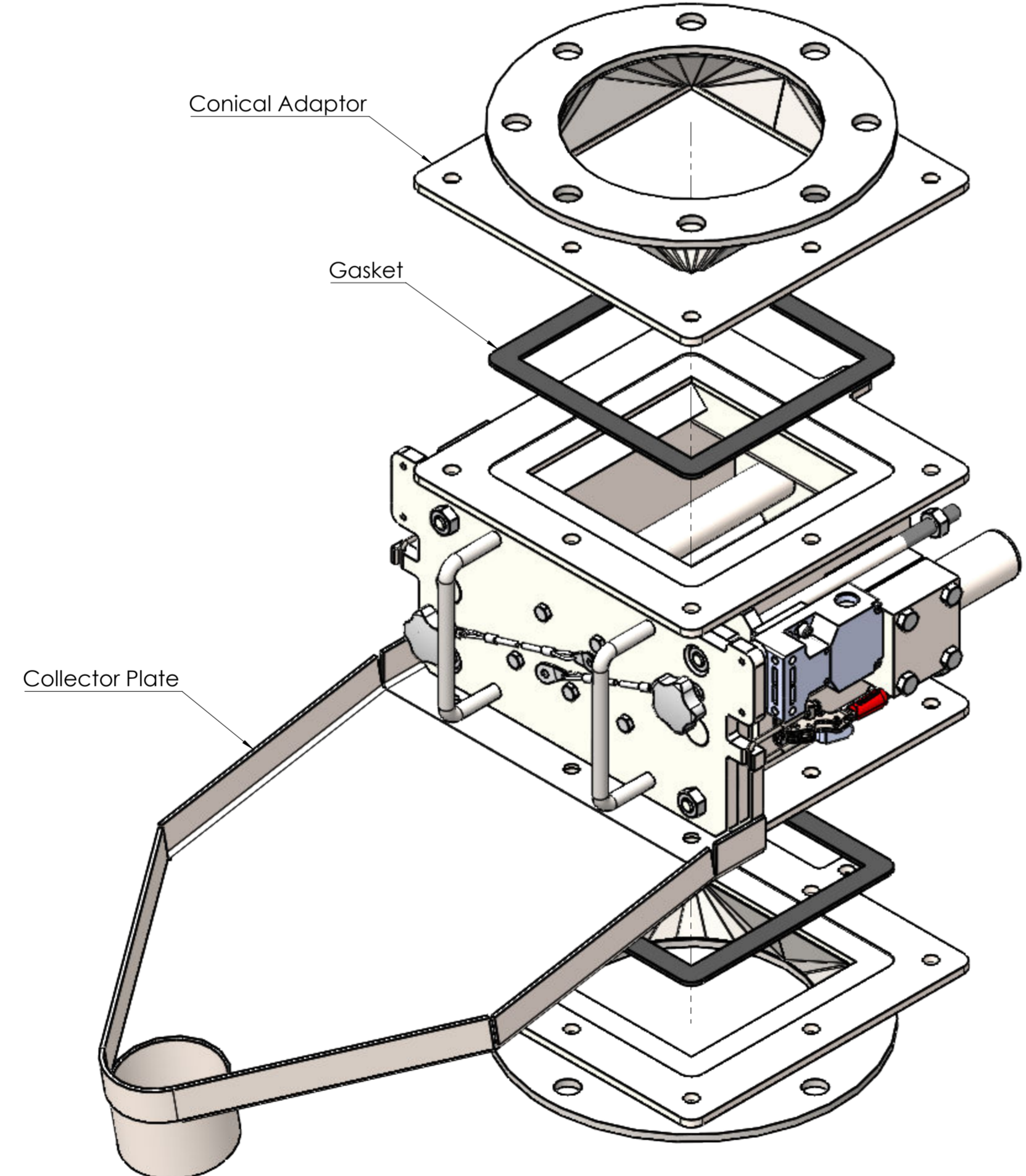
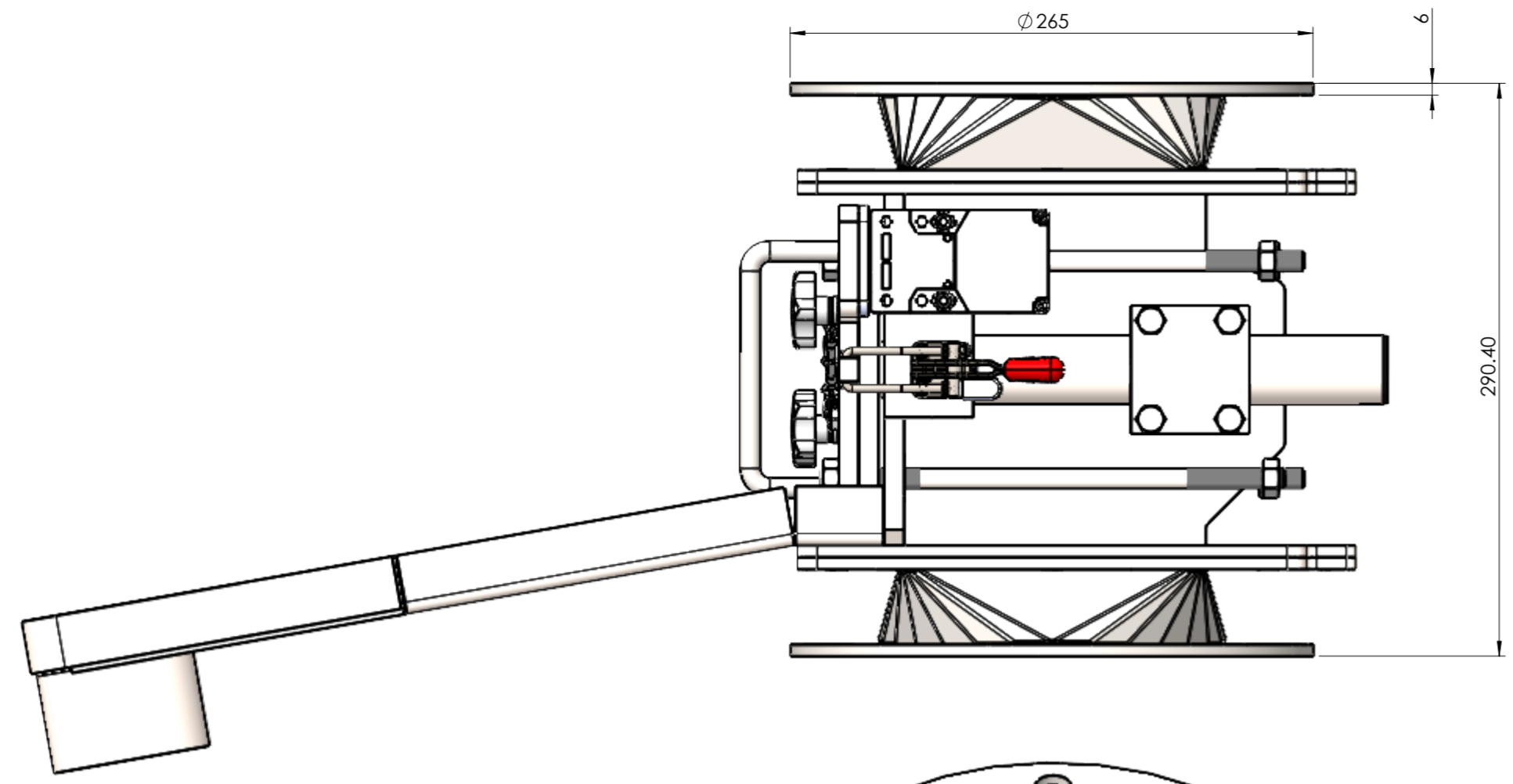

Title: MB_SA_F_150_With Adaptor		Article No.:	
Deburr and break sharp edges		ISO 2768m-k	Material:
 dutch magnetics <small>IN PARTNERSHIP WITH BRONNENBERG</small> Branchweg 3, 5705 DR Helmond, The Netherlands +31627746820 www.dutchmagnetics.com		Scale 1:3	Units: [mm] Treatment:
		Drwn By: SJ	Date: 03-05-2024 Finish:
		Appr By:	Date: Weight: kg
		Drawing No.: MB_SA_F_150_With Adaptor	
© Dutch Magnetics. All rights reserved. Reproduction in whole or parts is prohibited without the prior written permission of Dutch Magnetics.		State: Under Editing	A2 Rev: 0



12 11 10 9 8 7 6 5 4 3 2 1

REV.	DESCRIPTION	DATE	REV. BY
0			

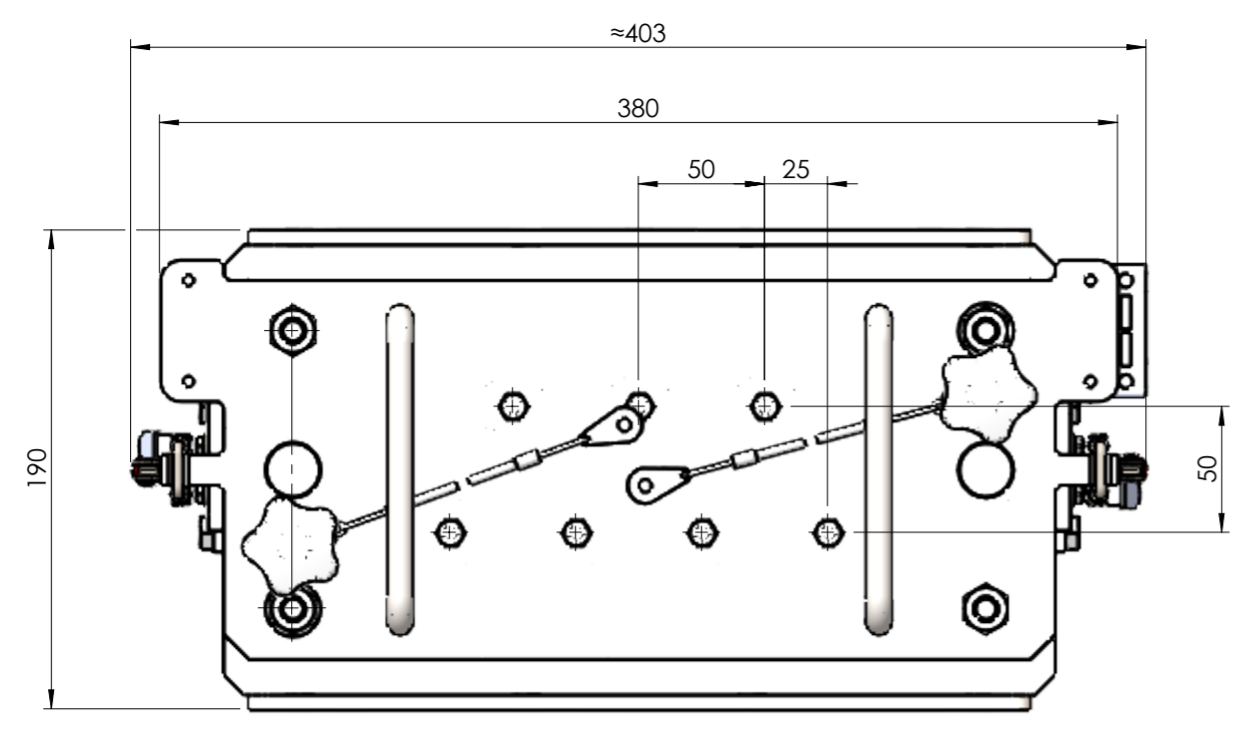

MAT. FLOW

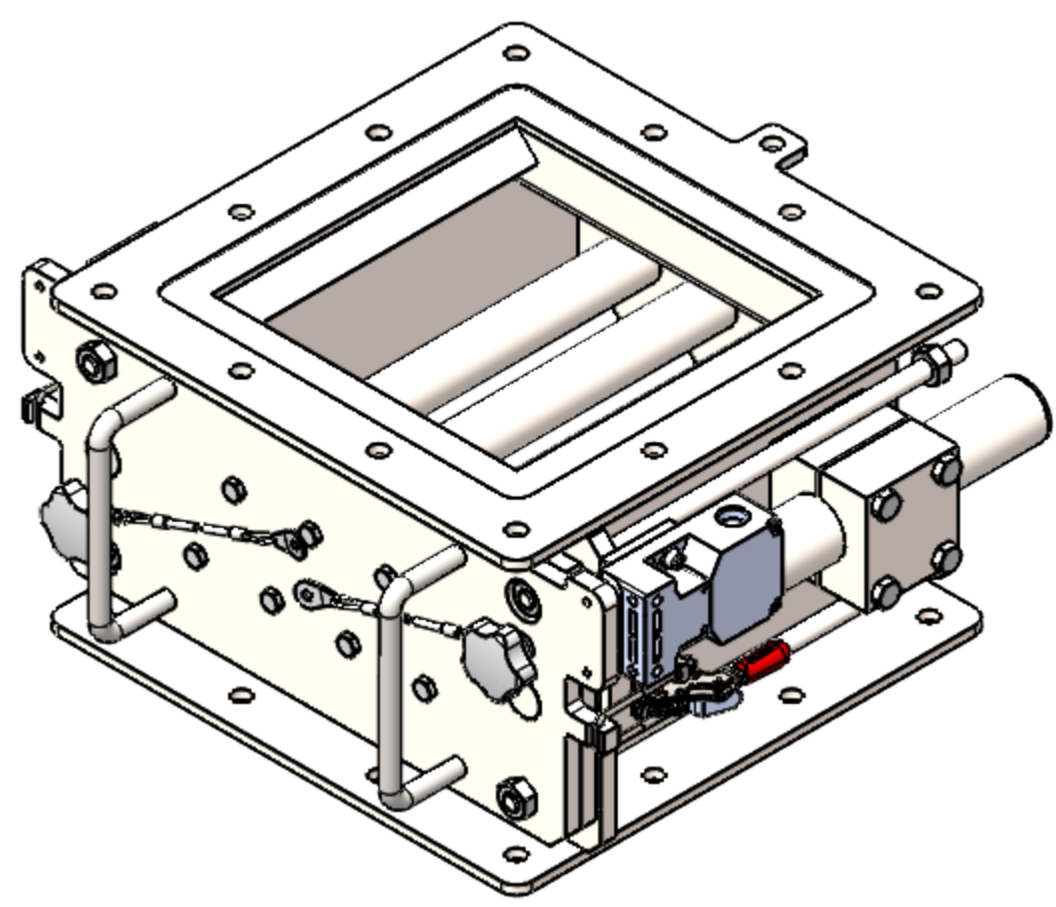
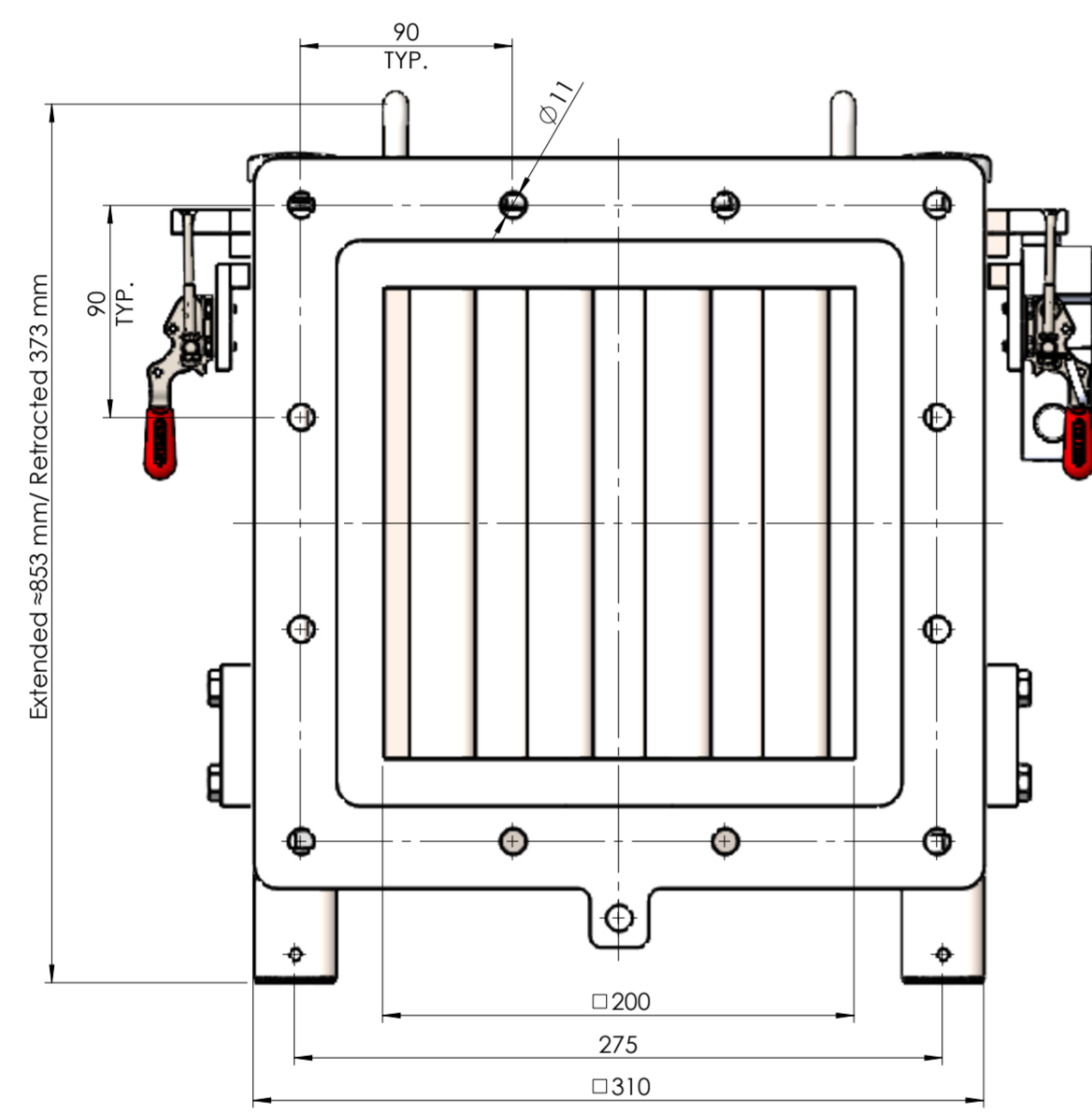
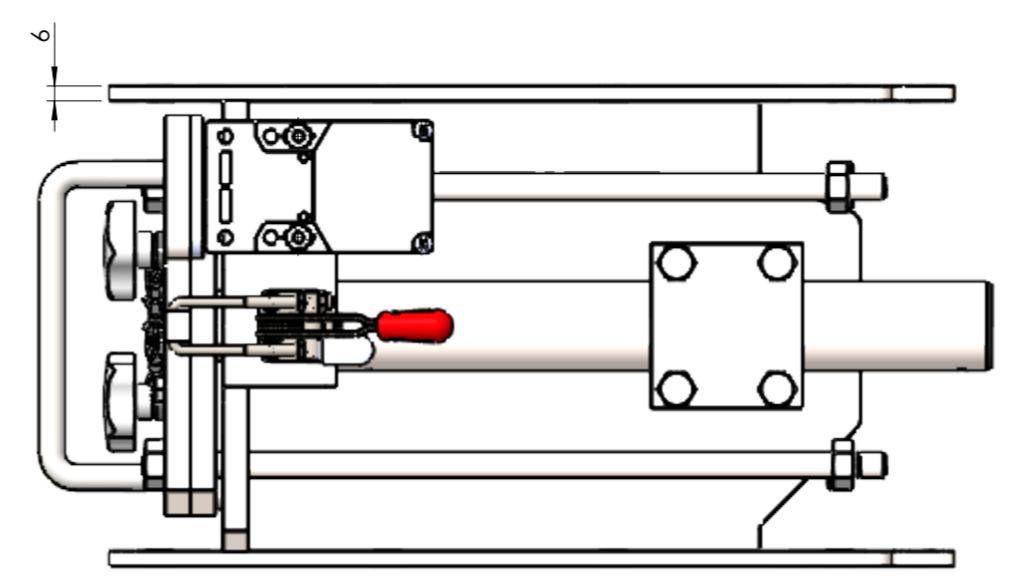
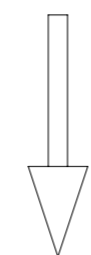

Magnet Specification	
Magnet Grade	48 H
Filter bar	Ø25
Quantity	7
Flux Density	>12000Gs
Structure Details	
Material	SS316L
Surface Treatment	Sublimation
Seal Material	Silicon
Finishing	Ra 32-4 µ in
Welding	Continuous with P240 radial polish
Recommended Parts	
DM202401642	Collector Plate
DM202402404	Conical Adaptor
DM202402442	Gasket for Rectangular Flanges

Notes:  
 Safety Position Switch : Schmersal Schakelaars EEX AZ16-12 ZVRK  
 Voltage : 230 VAC / 24 VDC (2x NC / 1x NO)

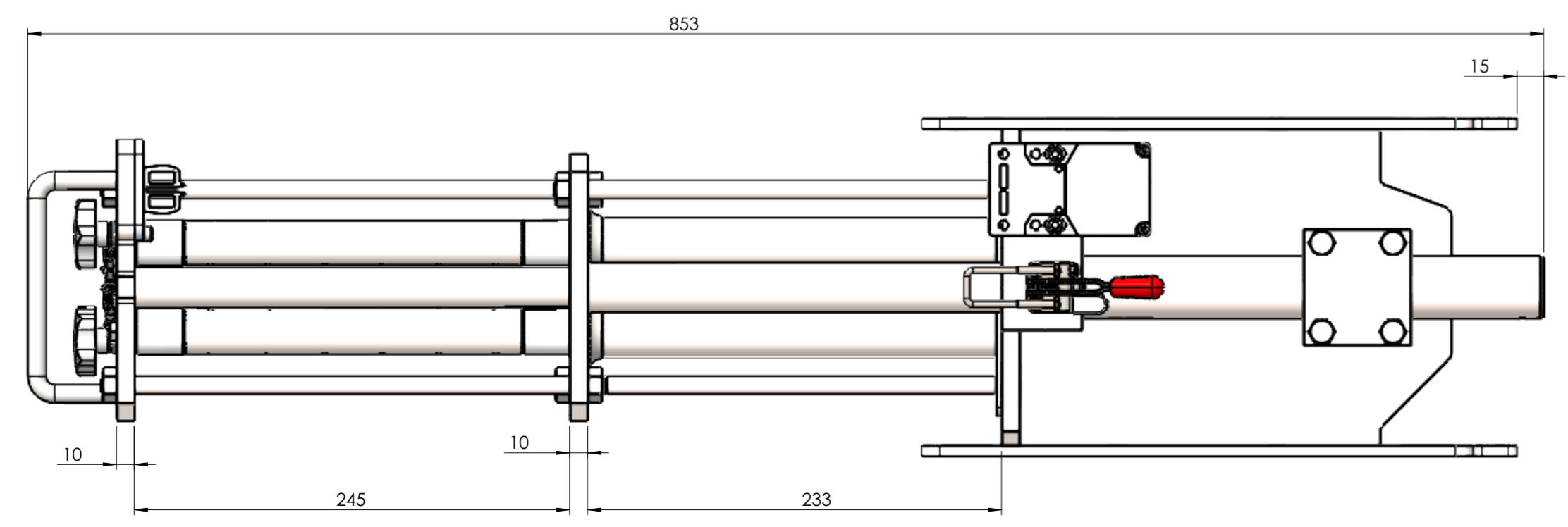

Title: Magbox Semi_Automatic FOOD GRADE 200		Article No.:	
Deburr and break sharp edges		ISO 2768m-k	Material:
 IN PARTNERSHIP WITH BRONNENBERG Branchweg 3, 5705 DR Helmond, The Netherlands +31627746820 www.dutchmagnetics.com	Scale 1:3	Units: [mm]	Treatment:
	Drwn By: SJ	Date: 03-05-2024	Finish:
Appr By:	Date:	Weight: 34.44 kg	<b>A2</b> Rev: 0
Drawing No.: MB_SA_F_200_Master Drawing		State: Under Editing	

12 11 10 9 8 7 6 5 4 3 2 1

REV.	DESCRIPTION	DATE	REV. BY
0			

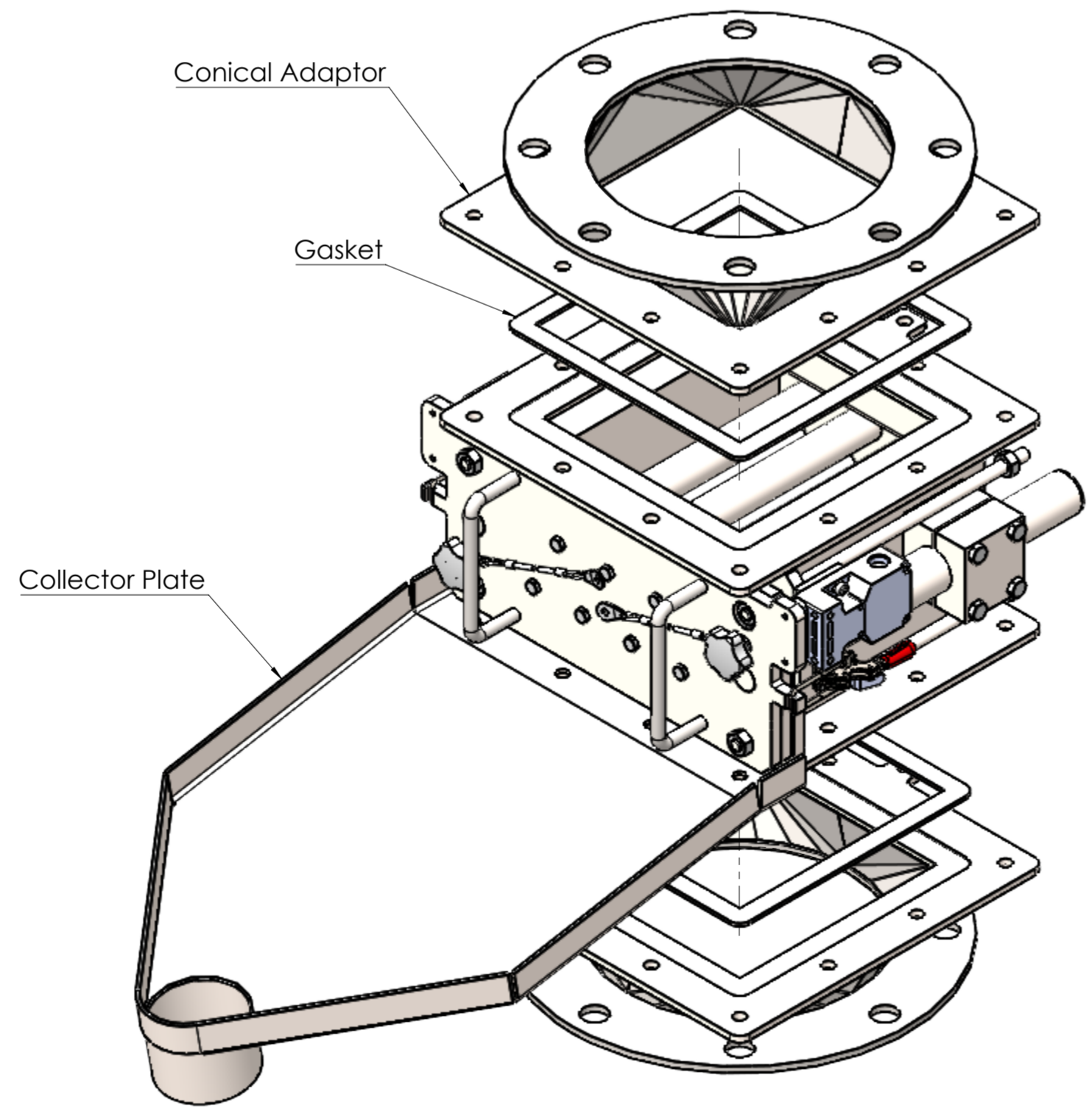
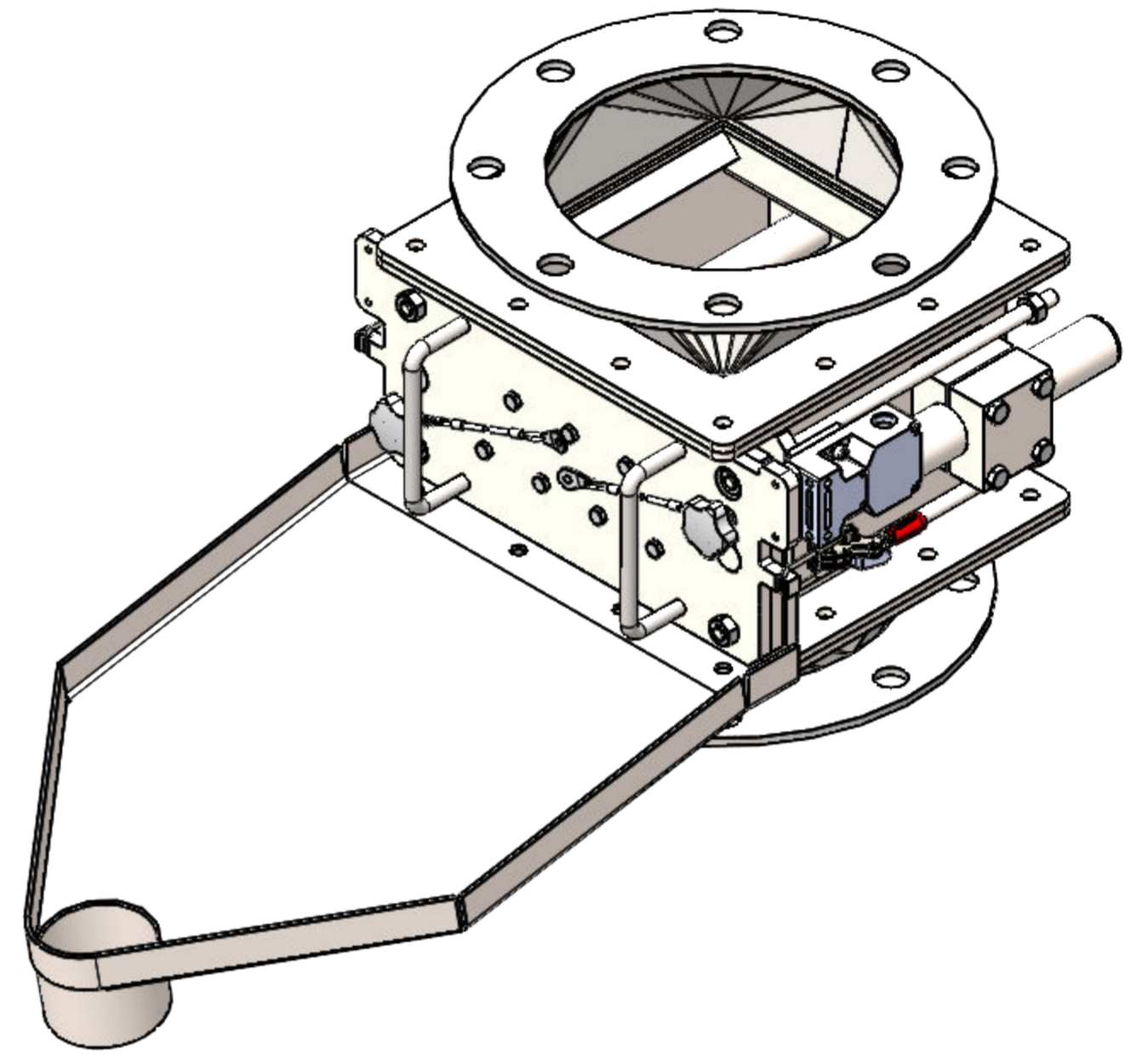
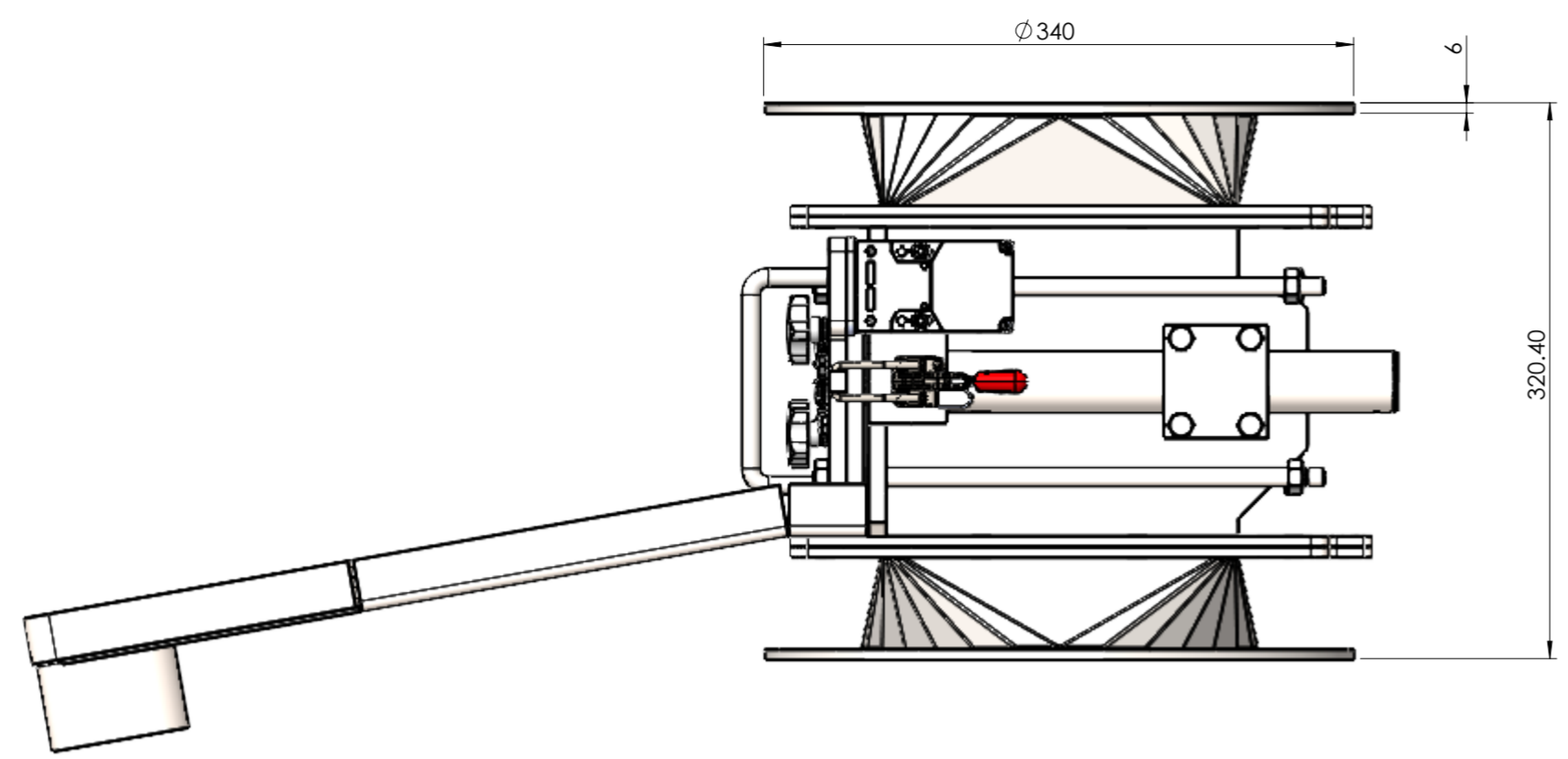

Title: MB_SA_F_200_With Adaptor		Article No.:	
Deburr and break sharp edges		ISO 2768m-k	Material:
 dutch magnetics <small>IN PARTNERSHIP WITH BRONNENBERG</small> Branchweg 3, 5705 DR Helmond, The Netherlands +31627746820 www.dutchmagnetics.com	Scale 1:3	Units: [mm]	Treatment:
	Drwn By: SJ	Date: 03-05-2024	Finish:
Appr By:	Date:	Weight: kg	<b>A2</b>
Drawing No.: MB_SA_F_200_With Adaptor			
State: Under Edifing			Rev: 0



REV.	DESCRIPTION	DATE	REV. BY
0			

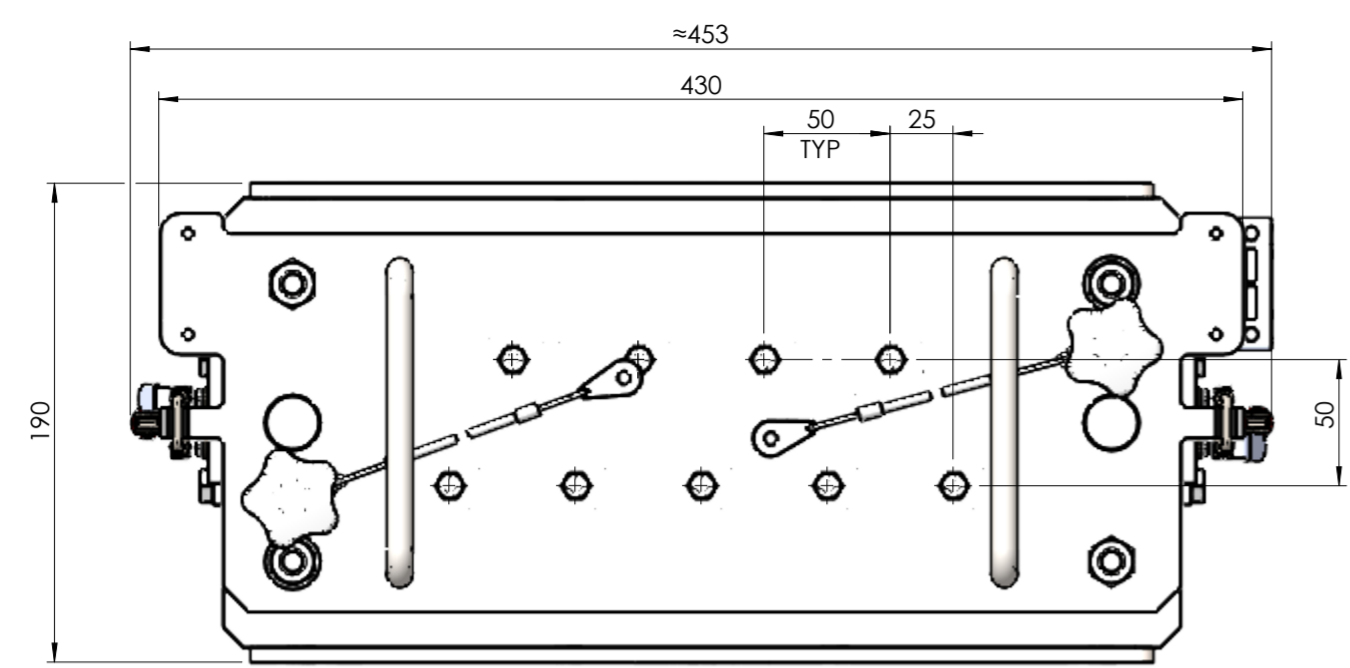

MAT. FLOW

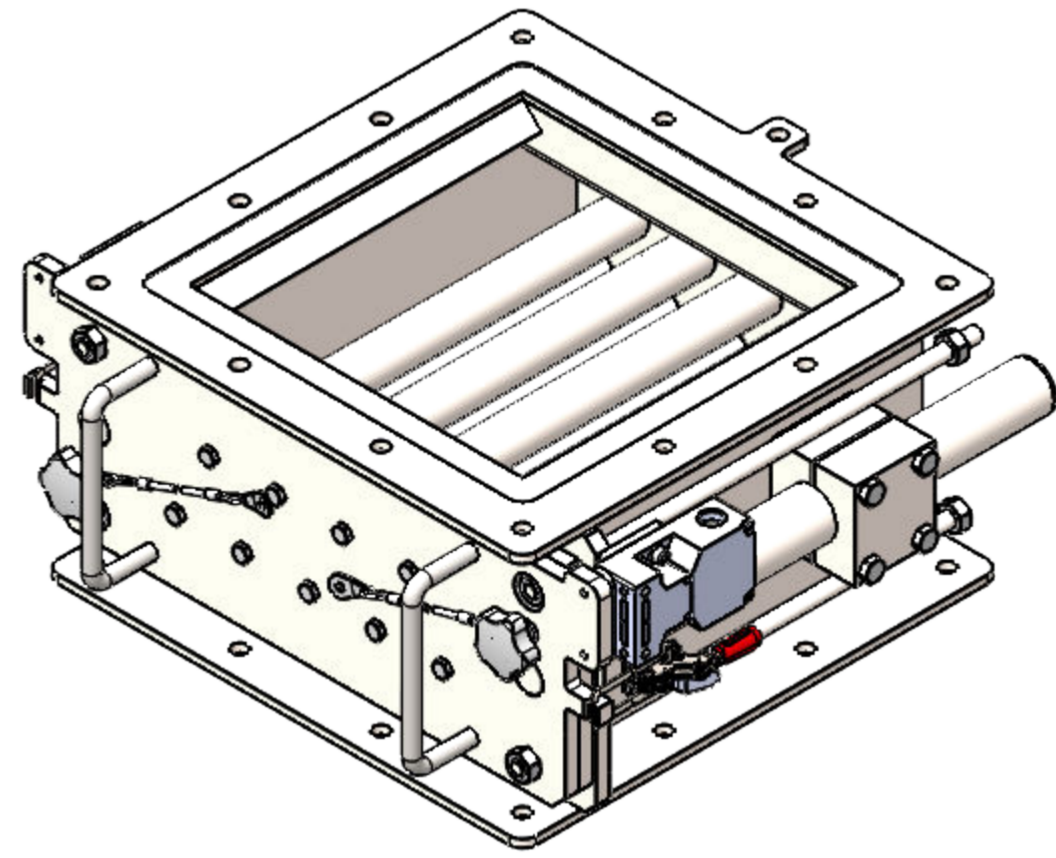
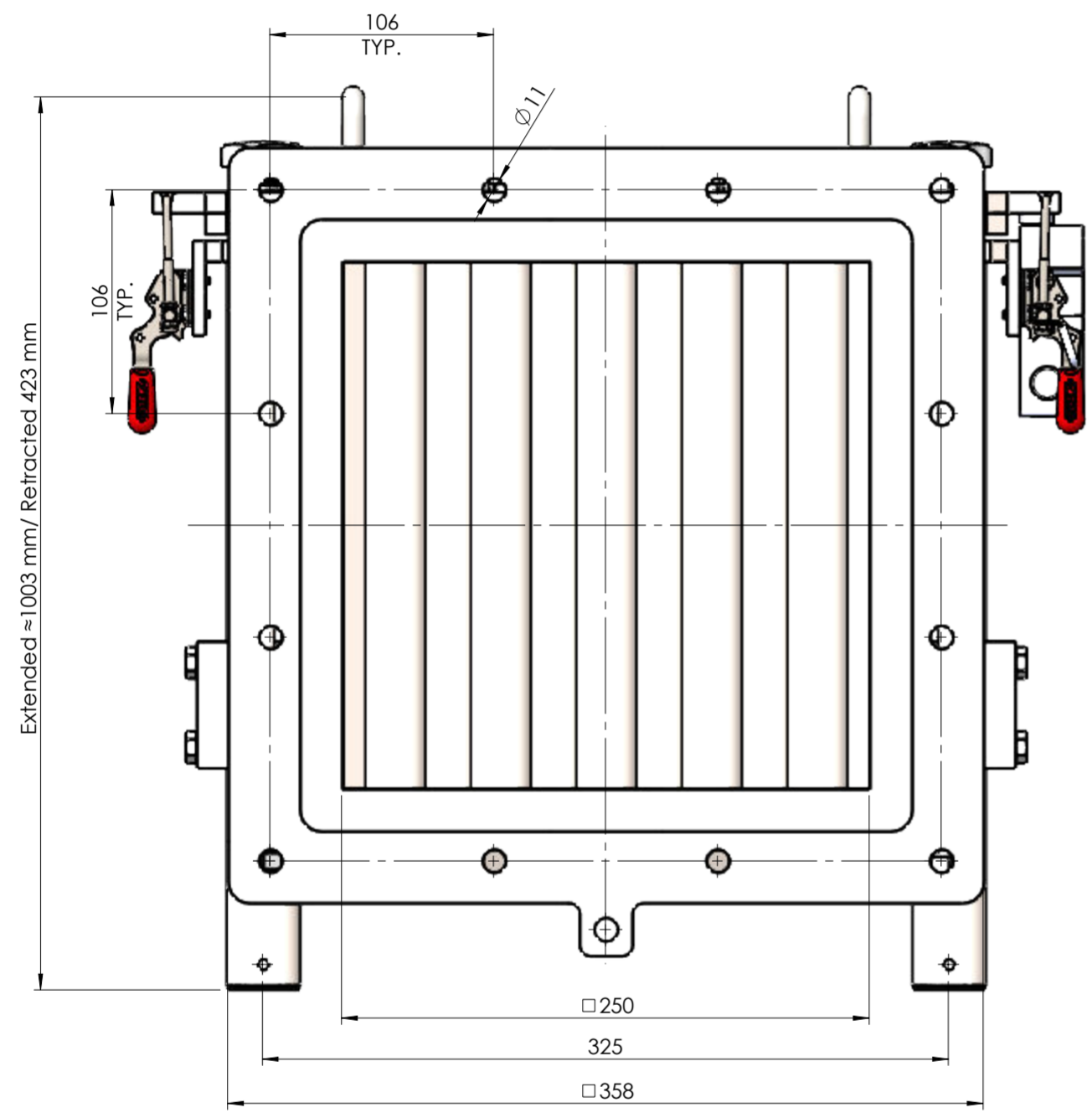
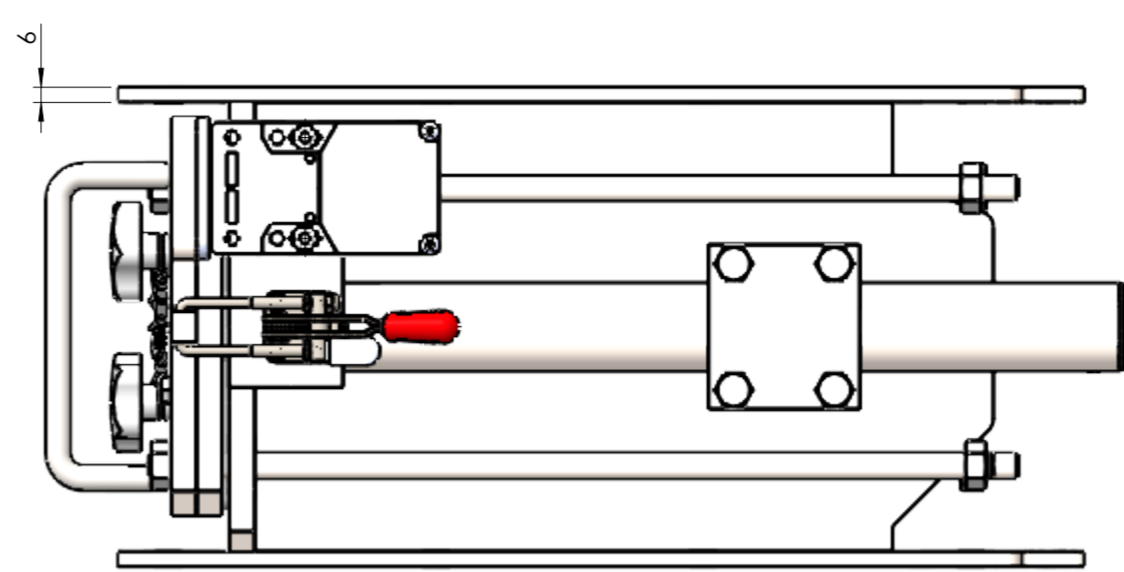
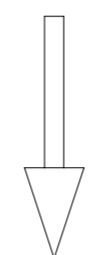

Magnet Specification	
Magnet Grade	48 H
Filter bar	Ø25
Quantity	9
Flux Density	>12000Gs
Structure Details	
Material	SS316L
Surface Treatment	Sublimation
Seal Material	Silicon
Finishing	Ra 32-4 µ in
Welding	Continuous with P240 radial polish
Recommended Parts	
DM202401641	Collector Plate
DM202402408	Conical Adaptor
DM202402443	Gasket for Rectangular Flanges

Notes:  
 Safety Position Switch : Schmersal Schakelaars EEX AZ16-12 ZVRK  
 Voltage : 230 VAC / 24 VDC (2x NC / 1x NO)

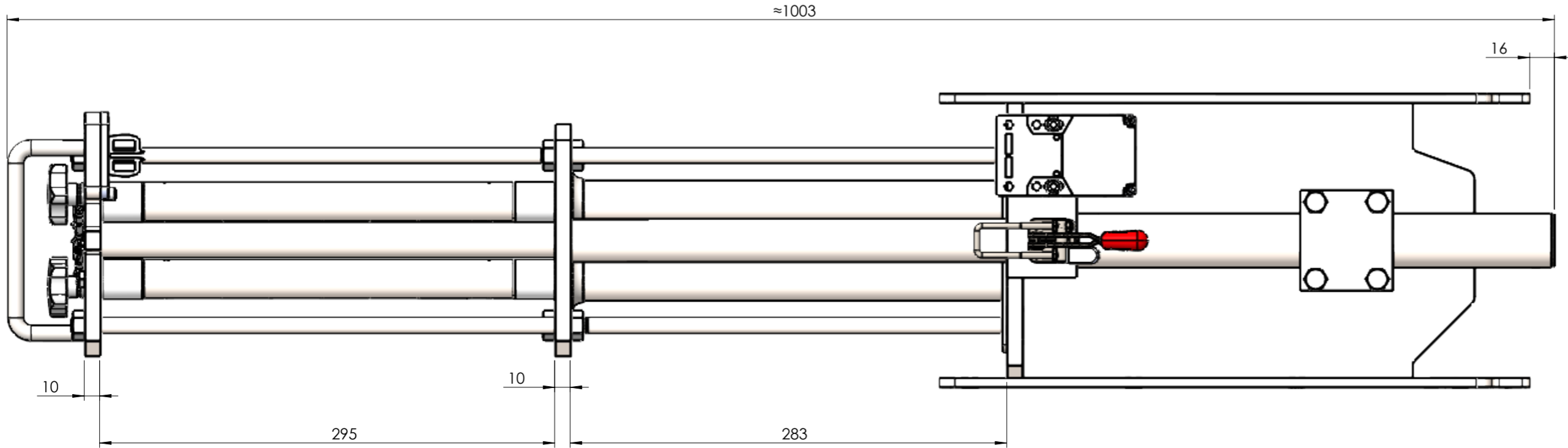

Title: Magbox Semi_Automatic FOOD GRADE 250		Article No.:	
Deburr and break sharp edges		ISO 2768m-k	Material:
 IN PARTNERSHIP WITH BRONNENBERG Branchweg 3, 5705 DR Helmond, The Netherlands +31627746820 www.dutchmagnetics.com	Scale 1:3	Units: [mm]	Treatment:
	Drwn By: SJ	Date: 03-05-2024	Finish:
Appr By:	Date:	Weight: 42.20 kg	<b>A2</b> Rev: 0
Drawing No.: MB_SA_F_250_Master Drawing		State: Under Editing	



12

11

10

9

8

7

6

5

4

3

2

1

REV.	DESCRIPTION	DATE	REV. BY
0			

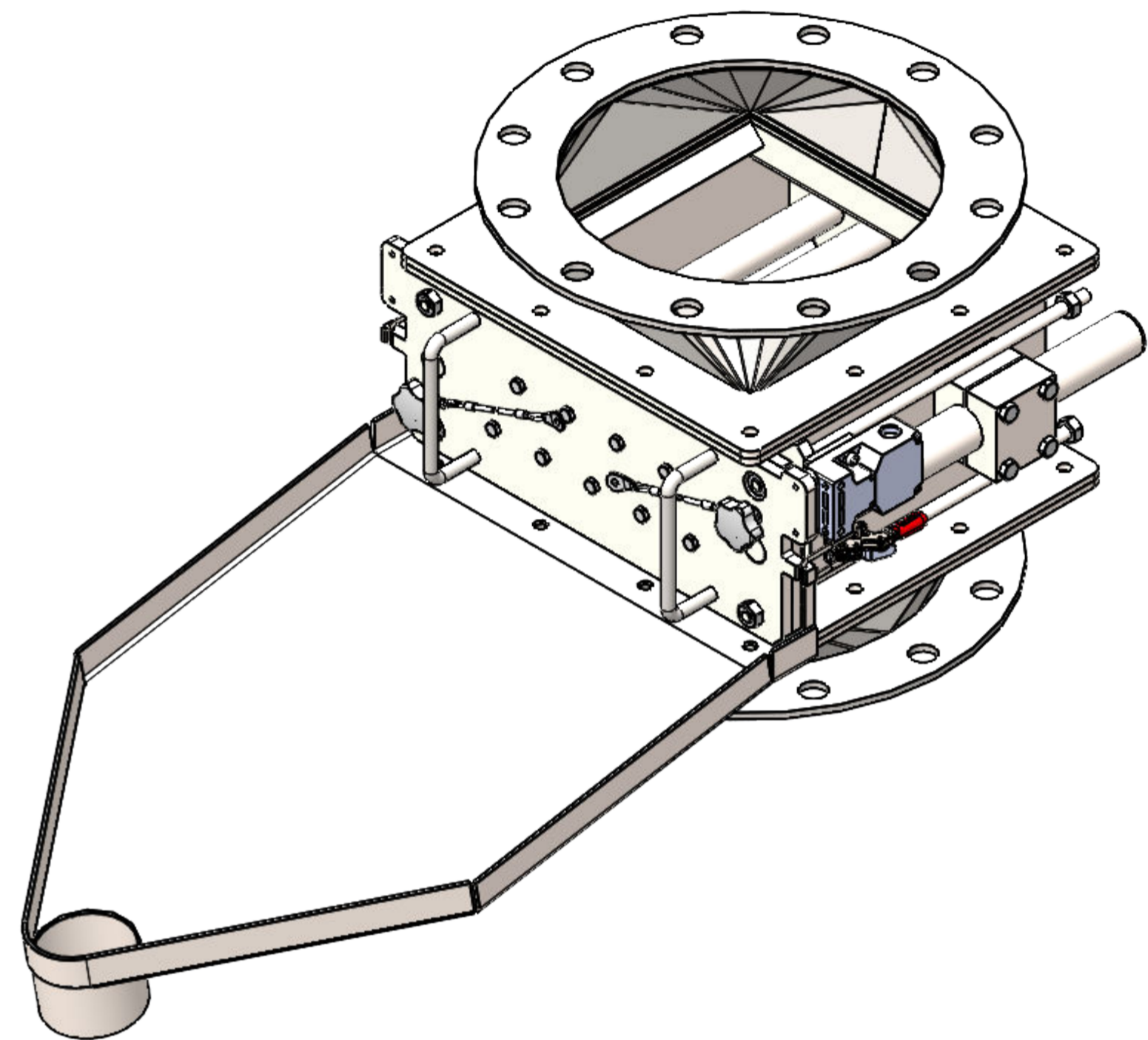
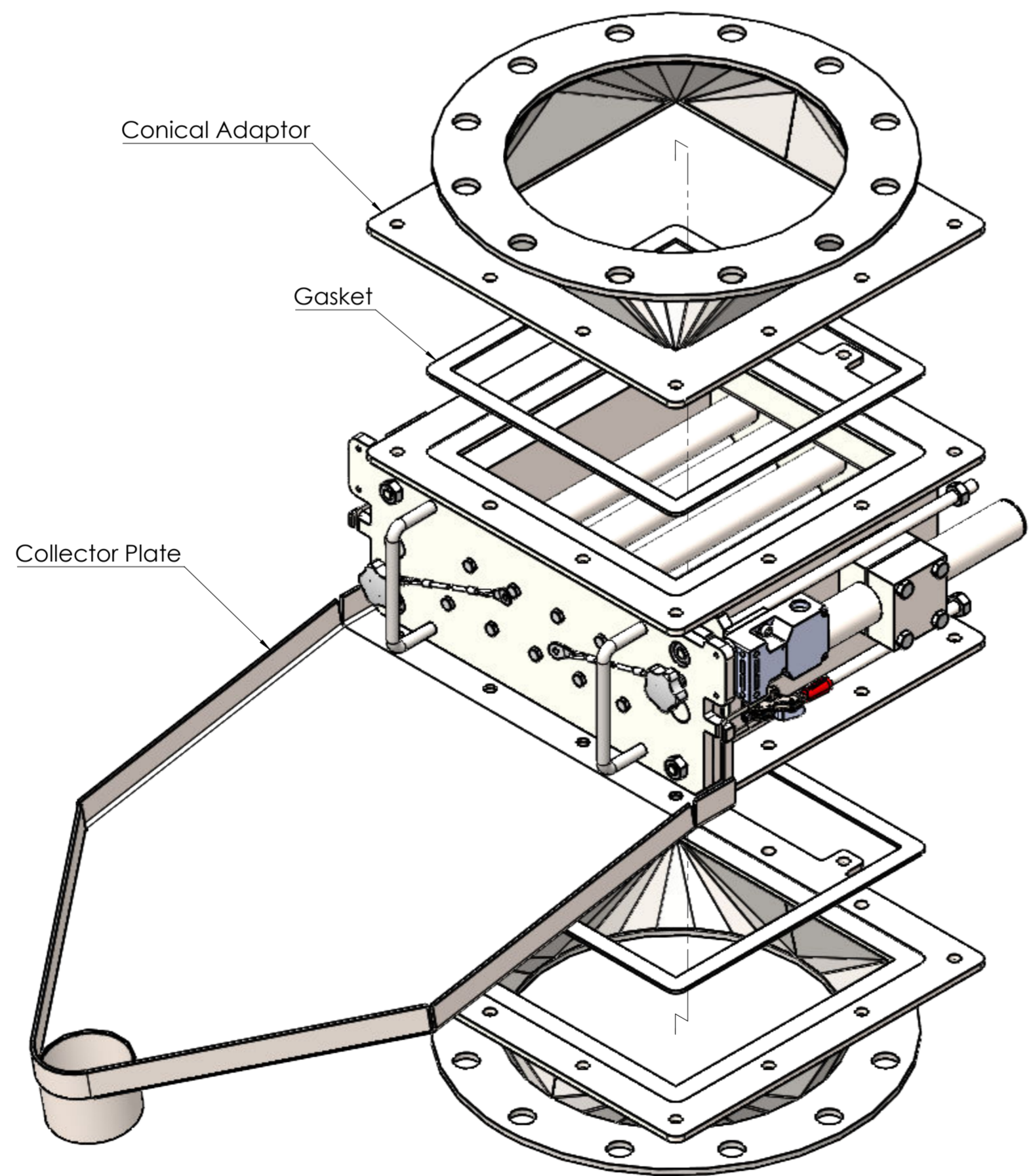
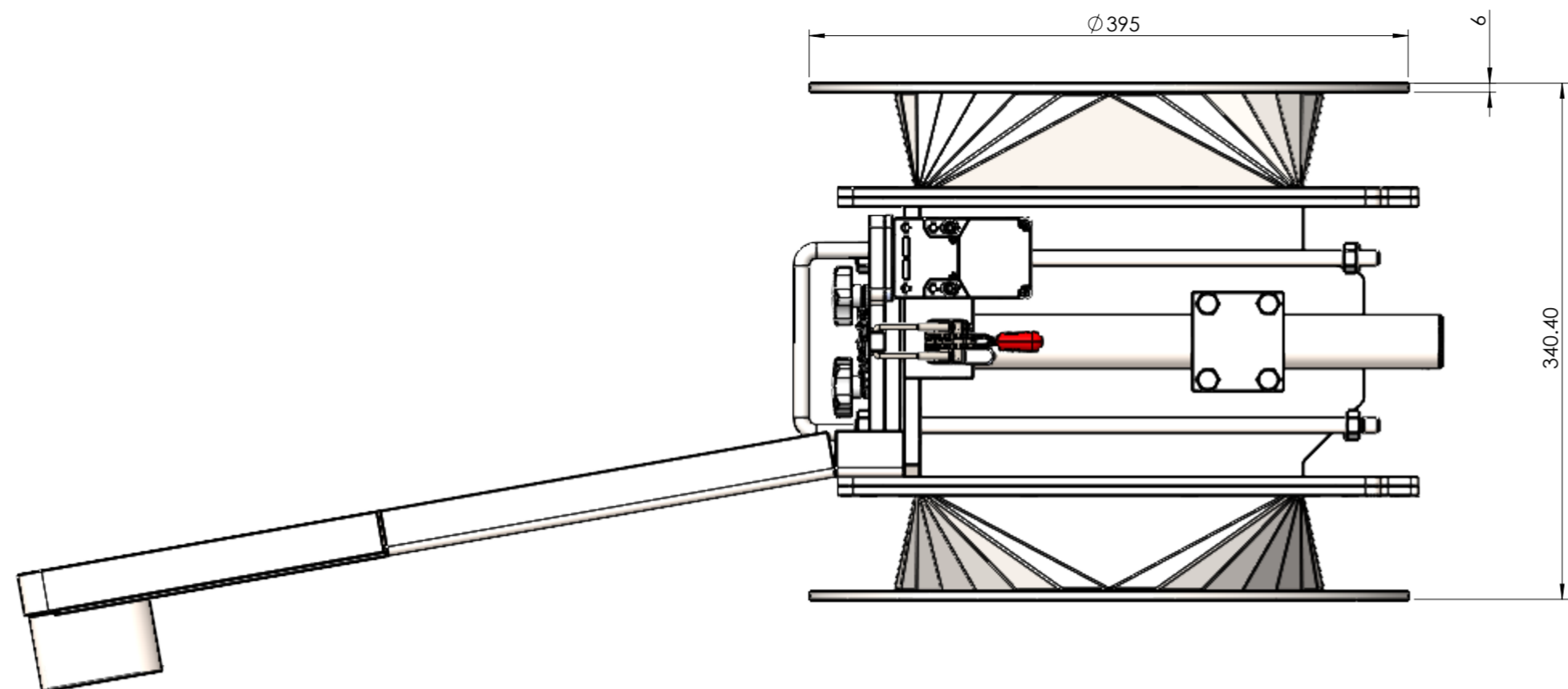

Title: MB_SA_F_250_With Adaptor		Article No.:	
Deburr and break sharp edges		ISO 2768m-k	Material:
	Scale 1:3	Units: [mm]	Treatment:
	Drwn By: SJ	Date: 03-05-2024	Finish:
Branchweg 3, 5705 DR Helmond, The Netherlands +31627746820 www.dutchmagnetics.com	Appr By:	Date:	Weight: kg
	Drawing No.: MB_SA_F_250_With Adaptor		<b>A2</b>
© Dutch Magnetics. All rights reserved. Reproduction in whole or parts is prohibited without the prior written permission of Dutch Magnetics.		State: Under Editing	Rev: 0

12

11

10

9

8

7

6

5

4

3

2

1



REV.	DESCRIPTION	DATE	REV. BY
0			

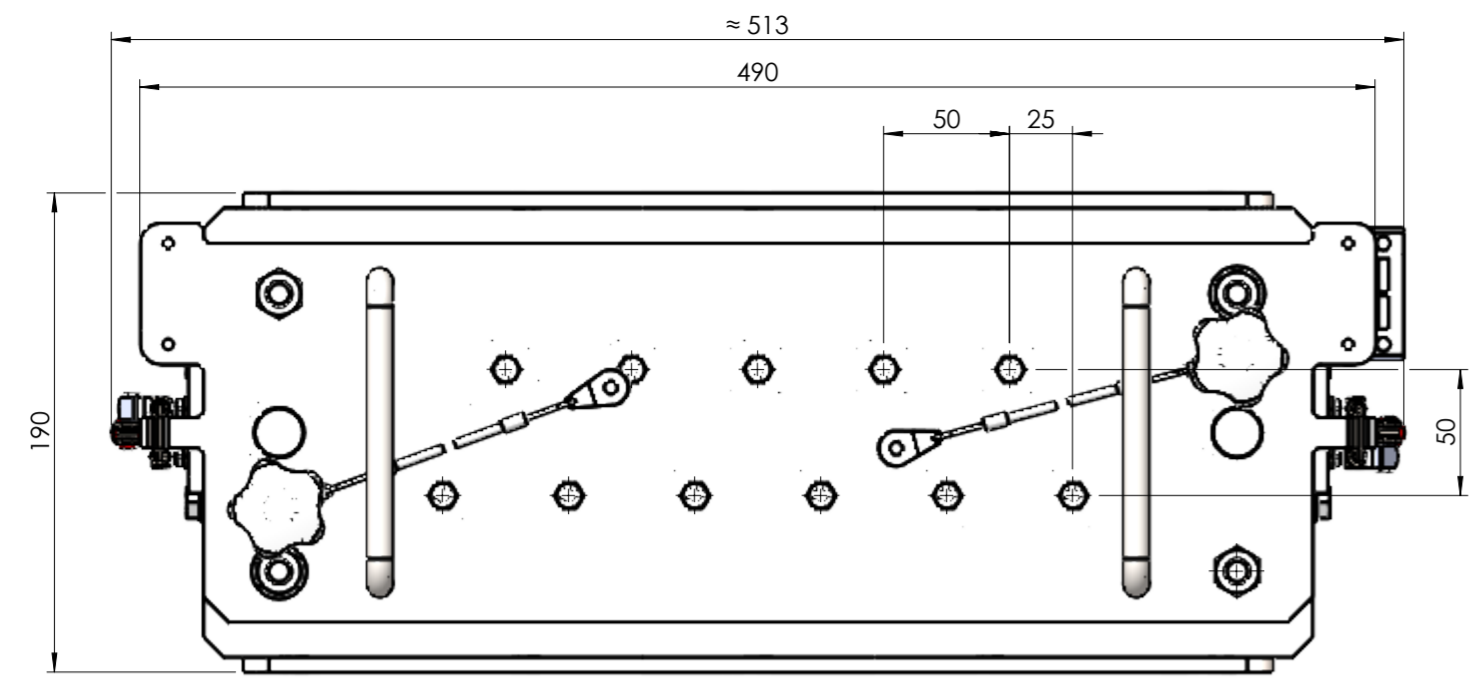

MAT. FLOW

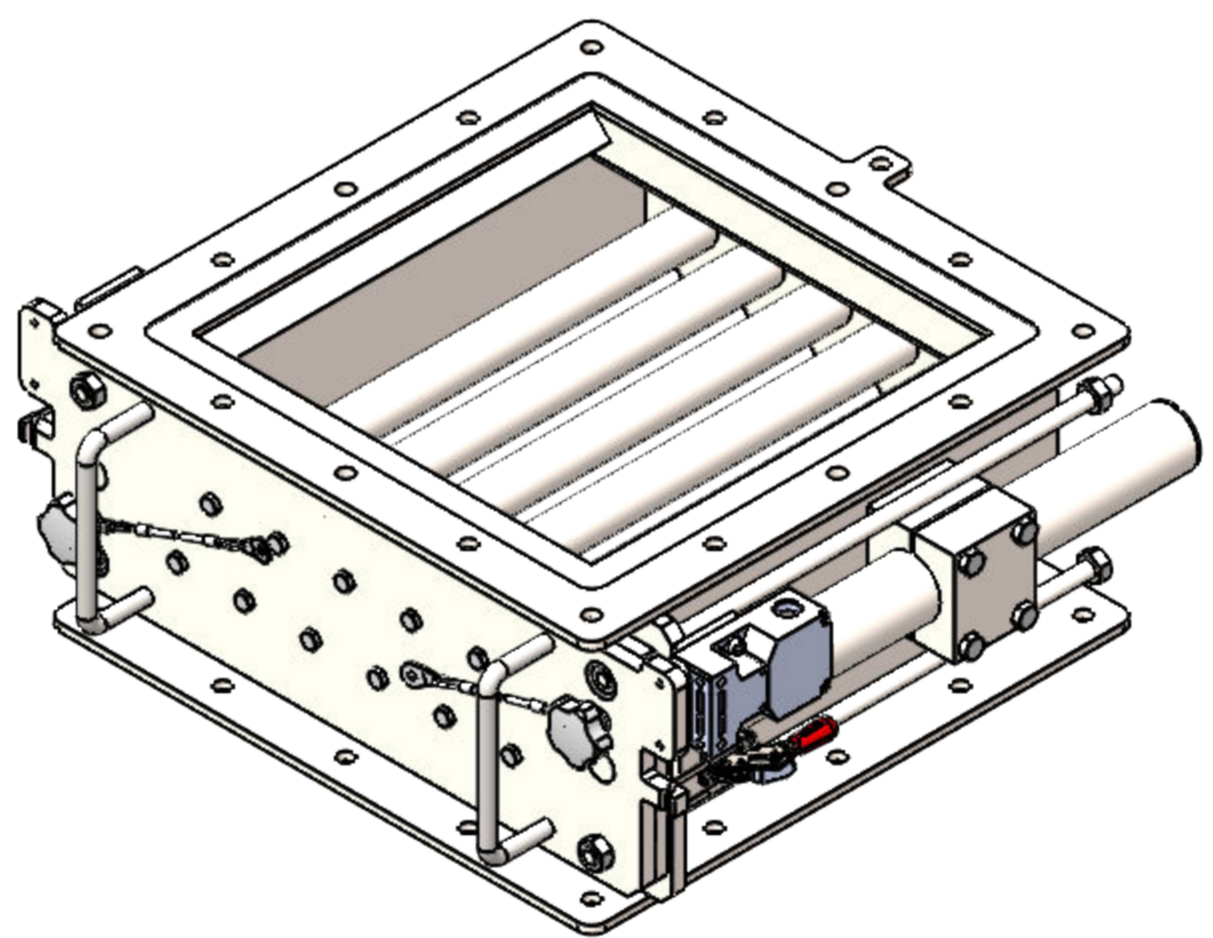
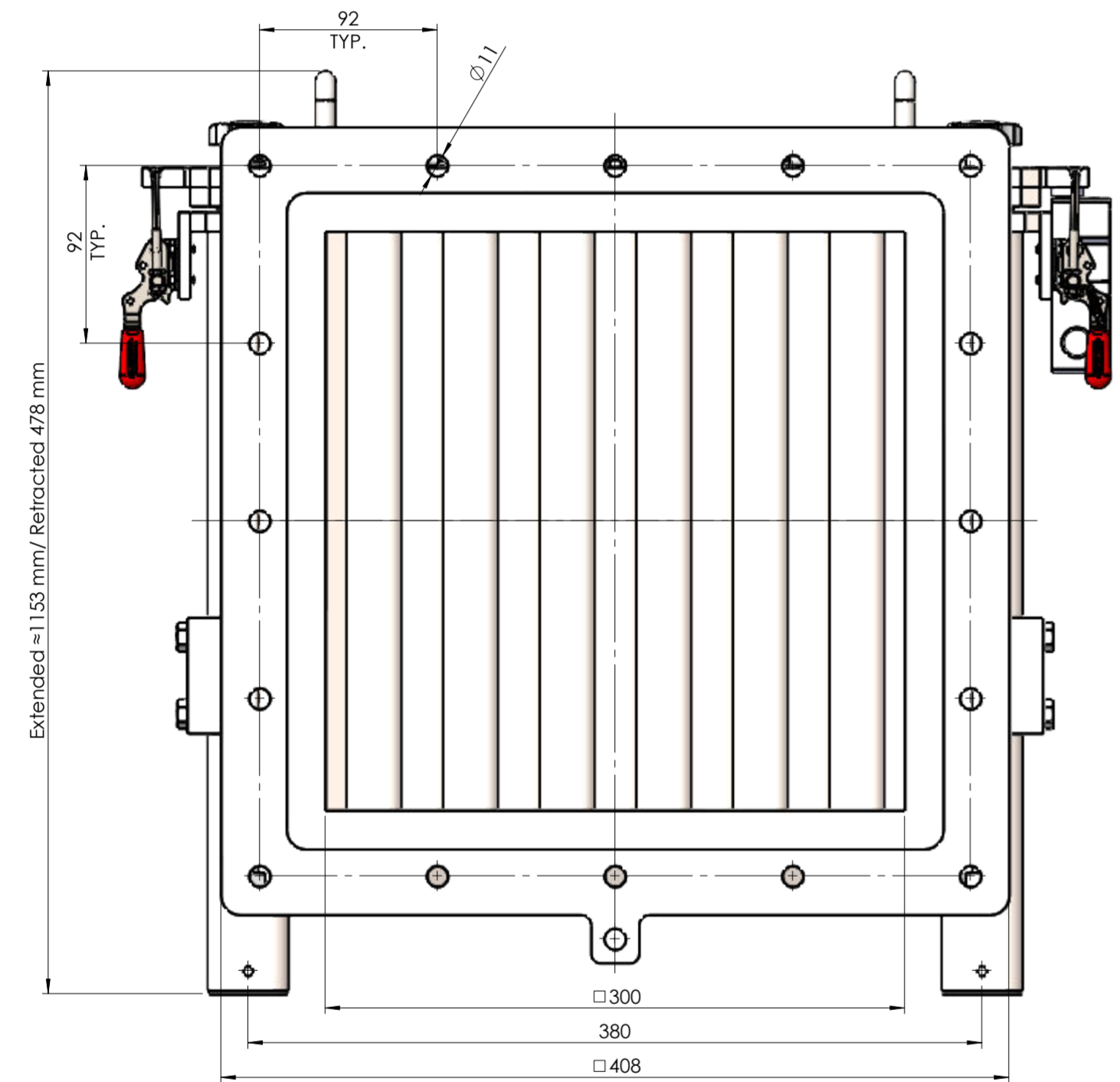
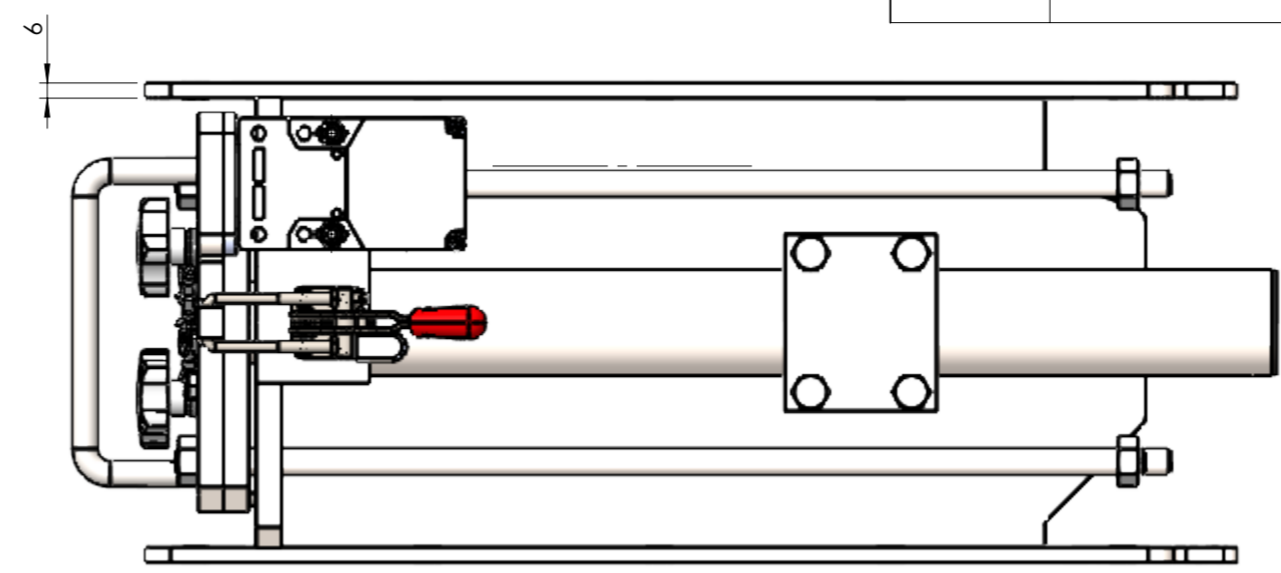
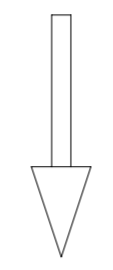

Magnet Specification	
Magnet Grade	48 H
Filter bar	$\phi 25$
Quantity	11
Flux Density	>12000Gs
Structure Details	
Material	SS316L
Surface Treatment	Sublimation
Seal Material	Silicon
Finishing	Ra 32-4 $\mu$ in
Welding	Continuous with P240 radial polish
Recommended Parts	
DM202401635	Collector Plate
DM202402414	Conical Adaptor
DM202402444	Gasket for Rectangular Flanges

Notes:  
 Safety Position Switch : Schmersal Schakelaars EEX AZ16-12 ZVRK  
 Voltage : 230 VAC / 24 VDC (2x NC / 1x NO)

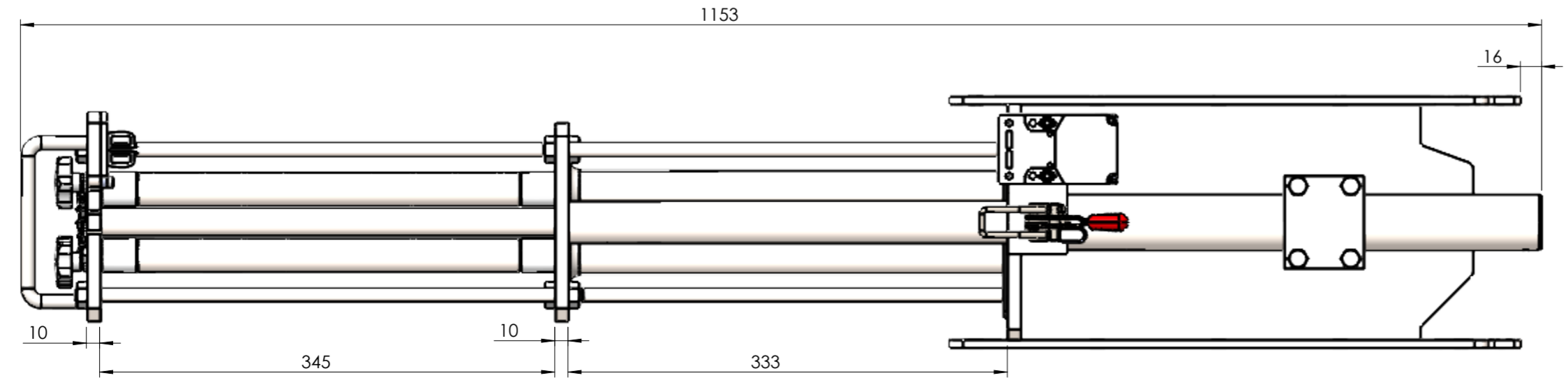

Title: Magbox Semi_Automatic FOOD GRADE 300		Article No.:	
Deburr and break sharp edges		ISO 2768m-k	Material:
 IN PARTNERSHIP WITH BRONNENBERG Branchweg 3, 5705 DR Helmond, The Netherlands +31627746820 www.dutchmagnetics.com	Scale 1:3	Units: [mm]	Treatment:
	Drwn By: SJ	Date: 03-05-2024	Finish:
Appr By:	Date:	Weight: 54.58 kg	A2
Drawing No.: MB_SA_F_300_Master Drawing			
State: Under Editing			Rev: 0



12

11

10

9

8

7

6

5

4

3

2

1

REV.	DESCRIPTION	DATE	REV. BY
0			

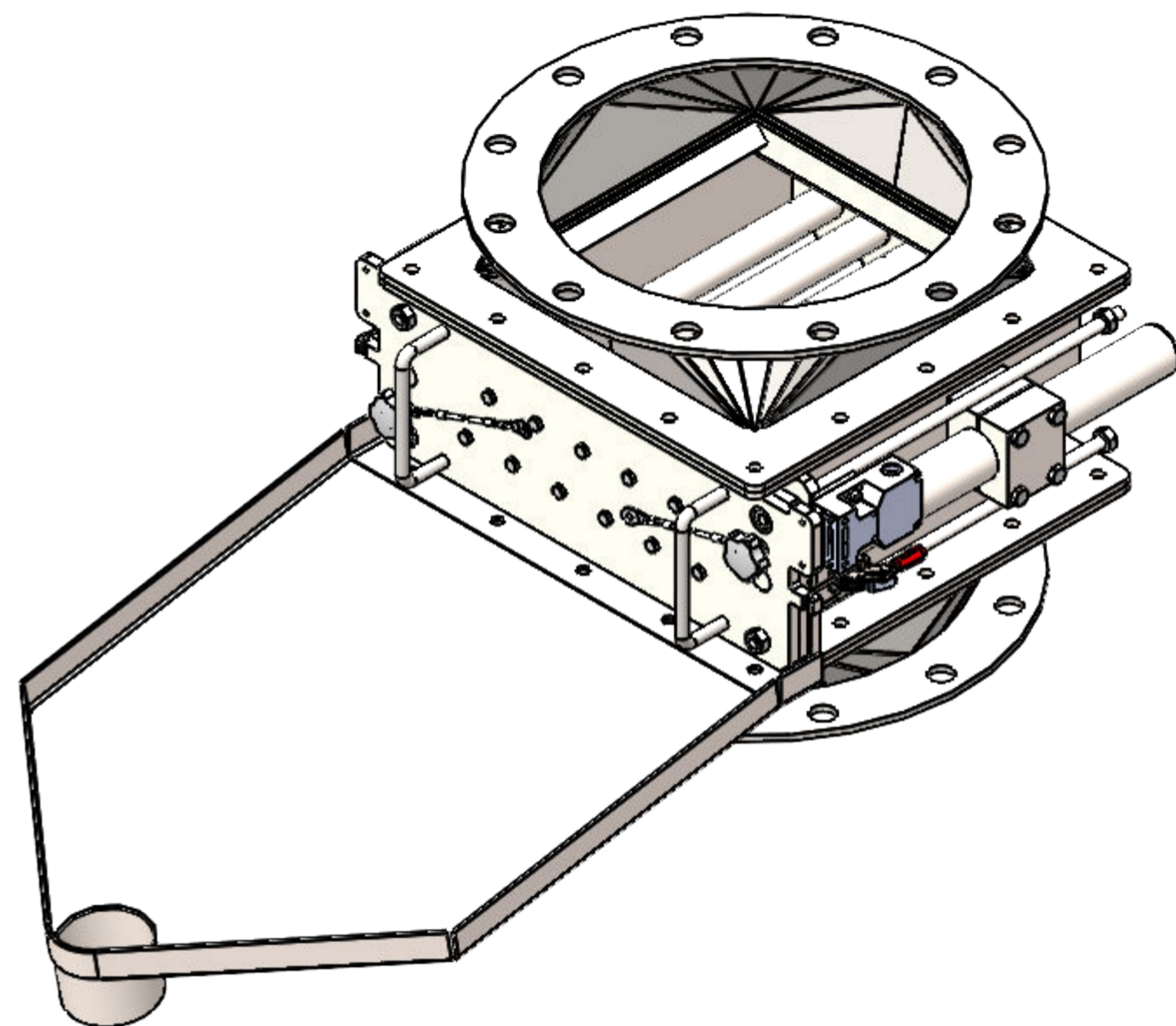
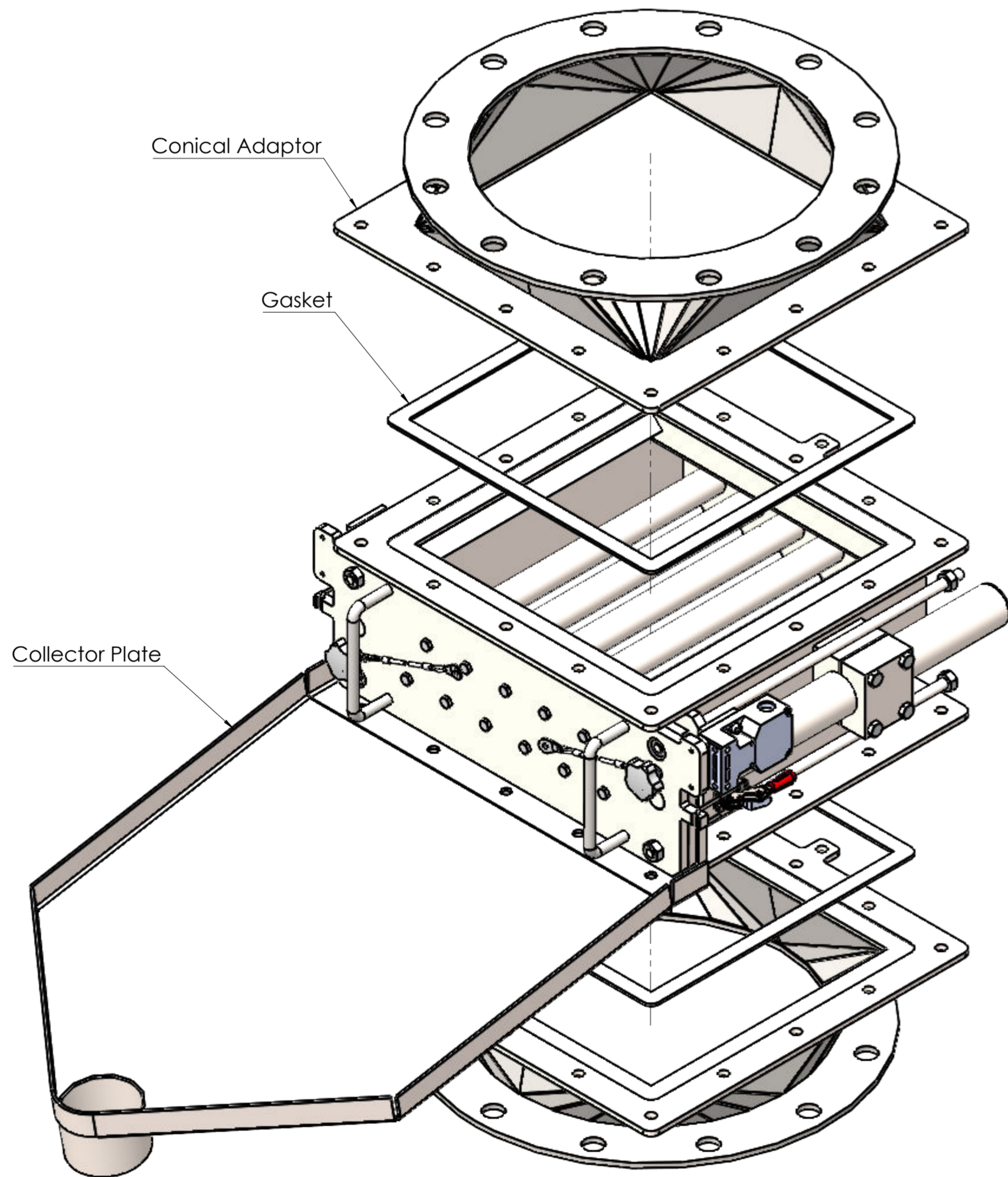
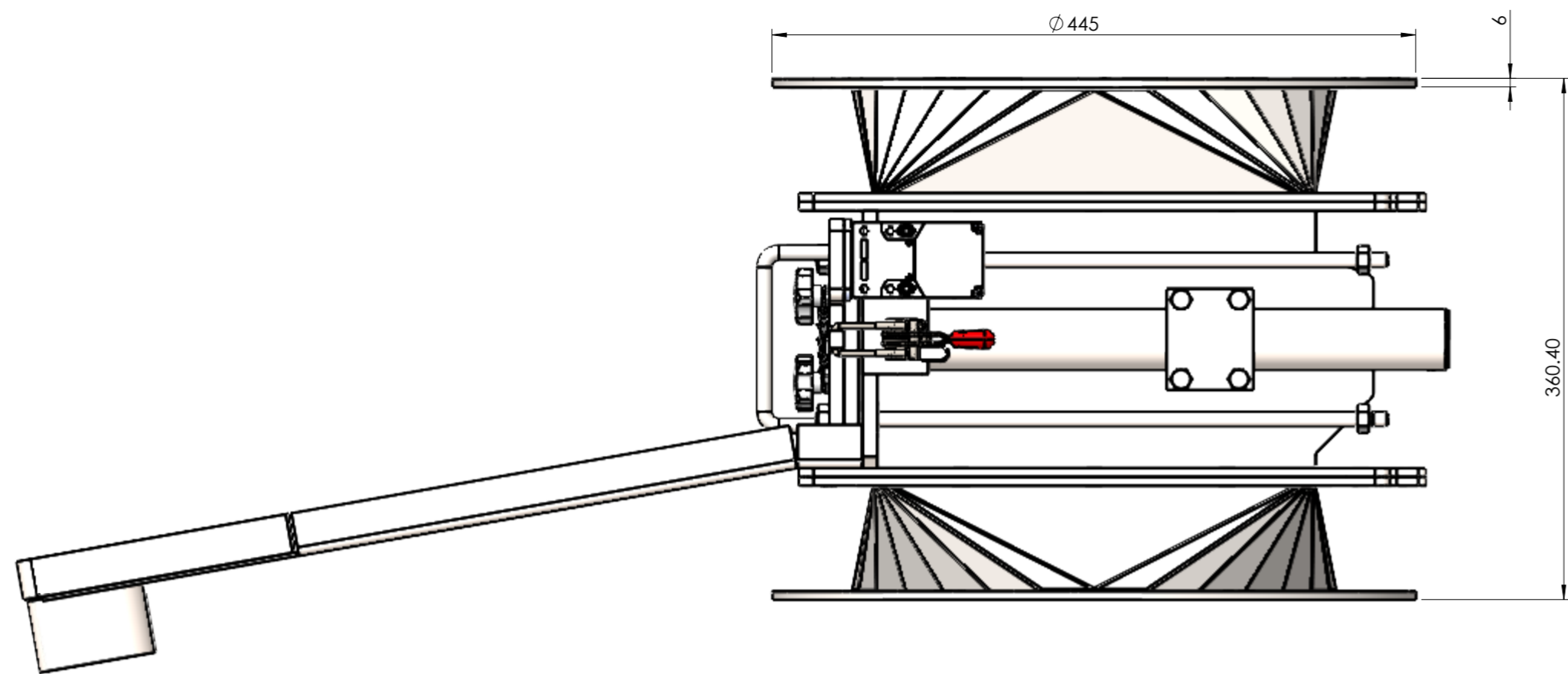

Title: MB_SA_F_300_With Adaptor		Article No.:	
Deburr and break sharp edges		ISO 2768m-k	Material:
	Scale 1:3	Units: [mm]	Treatment:
	Drwn By: SJ	Date: 03-05-2024	Finish:
Branchweg 3, 5705 DR Helmond, The Netherlands +31627746820 www.dutchmagnetics.com	Appr By:	Date:	Weight: kg
	Drawing No.: MB_SA_F_300_With Adaptor		<b>A2</b>
© Dutch Magnetics. All rights reserved. Reproduction in whole or parts is prohibited without the prior written permission of Dutch Magnetics.		State: Under Editing	Rev: 0

12

11

10

9

8

7

6

5

4

3

2

1